

По вопросам продаж и поддержки обращайтесь:

Алматы (7273)495-231
Ангарск (3955)60-70-56
Архангельск (8182)63-90-72
Астрахань (8512)99-46-04
Барнаул (3852)73-04-60
Белгород (4722)40-23-64
Благовещенск (4162)22-76-07
Брянск (4832)59-03-52
Владивосток (423)249-28-31
Владикавказ (8672)28-90-48
Владимир (4922)49-43-18
Волгоград (844)278-03-48
Вологда (8172)26-41-59
Воронеж (473)204-51-73
Екатеринбург (343)384-55-89
Иваново (4932)77-34-06
Ижевск (3412)26-03-58
Иркутск (395)279-98-46
Казань (843)206-01-48

Калининград (4012)72-03-81
Калуга (4842)92-23-67
Кемерово (3842)65-04-62
Киров (8332)68-02-04
Коломна (4966)23-41-49
Кострома (4942)77-07-48
Краснодар (861)203-40-90
Красноярск (391)204-63-61
Курган (3522)50-90-47
Курск (4712)77-13-04
Липецк (4742)52-20-81
Магнитогорск (3519)55-03-13
Москва (495)268-04-70
Мурманск (8152)59-64-93
Набережные Челны (8552)20-53-41
Нижний Новгород (831)429-08-12
Новокузнецк (3843)20-46-81
Новосибирск (383)227-86-73
Ноябрьск(3496)41-32-12

Омск (3812)21-46-40
Орел (4862)44-53-42
Оренбург (3532)37-68-04
Пенза (8412)22-31-16
Пермь (342)205-81-47
Петрозаводск (8142)55-98-37
Псков (8112)59-10-37
Ростов-на-Дону (863)308-18-15
Рязань (4912)46-61-64
Самара (846)206-03-16
Санкт-Петербург (812)309-46-40
Саранск (8342)22-96-24
Саратов (845)249-38-78
Севастополь (8692)22-31-93
Симферополь (3652)67-13-56
Смоленск (4812)29-41-54
Сочи (862)225-72-31
Ставрополь (8652)20-65-13
Сургут (3462)77-98-35

Сыктывкар (8212)25-95-17
Тамбов (4752)50-40-97
Тверь (4822)63-31-35
Тольятти (8482)63-91-07
Томск (3822)98-41-53
Тула (4872)33-79-87
Тюмень (3452)66-21-18
Улан-Удэ (3012)59-97-51
Ульяновск (8422)24-23-59
Уфа (347)229-48-12
Хабаровск (4212)92-98-04
Чебоксары (8352)28-53-07
Челябинск (351)202-03-61
Череповец (8202)49-02-64
Чита (3022)38-34-83
Якутск (4112)23-90-97
Ярославль (4852)69-52-93

Россия +7(495)268-04-70

Казахстан +7(7172)727-132

Киргизия +996(312)96-26-47

сайт: www.honeywell.nt-rt.ru || эл. почта: hwn@nt-rt.ru

БЕСПРОВОДНЫЕ ДАТЧИКИ

Технические характеристики

на XYR 6000 STUW750



SmartLine STUW750 / STUW751 Wireless Universal I/O Transmitter Specification

34-SW-03-12

Models:

STUW750

- Up to 3 channels of inputs for T/C's or mV.
- Up to 3 channels for High Level Analog Input.
- Up to 3 channels for discrete input or 2 wire resistance.

STUW751

- Up to 2 channels of inputs for T/C's or mV.
- Up to 2 channels for High Level Analog Input.
- Up to 2 channels for discrete input or 2 wire resistance.
- Plus 1 dedicated channel for digital output.

Introduction

SmartLine Wireless Universal I/O Transmitter continues the evolution of Honeywell's wireless transmitter product offering and provides the latest critical advancements to support industrial automation users' desire to expand wireless use for monitoring and control.

With over 14 years of industrial wireless experience, the SmartLine Wireless Universal I/O builds upon and is compatible with the current XYR 6000 product portfolio. Similar to the XYR 6000 wireless transmitter, the SmartLine Wireless product line is part of the Honeywell OneWireless™ system and is ISA100 - ready.

The SmartLine Wireless Universal I/O transmitter enables customers to obtain data and create information from remote and hazardous measurement locations without the need to run wires, where running wire is cost prohibitive and/or the measurement is in a hazardous location. Without wires, transmitters can be installed and operational in minutes, quickly providing information back to your system.



Figure 1 — SmartLine Wireless Universal I/O

The previous generation transmitters primarily were applied to monitoring applications but experienced users know that Honeywell's wireless products are as reliable, secure, and safe as their wired counterparts. With this knowledge, users are now looking for wireless transmitters for use in specific control applications.

SmartLine Wireless introduces a step change in performance and most notably, performance suitable for control. SmartLine Wireless performance is improved in these ways:

- Fast ½ second publication rate.
- Higher radio range coverage.
- More powerful 4 dBi integral antenna.
- Smarter local display with more local diagnostics and radio signal and quality indicators.
- More input channels and types than earlier.

SmartLine Wireless Universal I/O retains the following desirable features from the XYR 6000 product offering:

- Mesh or non-mesh configuration within each transmitter.
- Generic, off-the-shelf lithium ion battery.
- Two “D” size batteries for longer life.
- Choice of over-the-air or local provisioning (network security join key)
- Over-the-air firmware upgrade capability
- Unique, encrypted provisioning key delivered from the factory.
- Remote and integral antenna options.
- 24 VDC power option.
- Publication rates of 1, 5, 10, or 30 seconds, plus new selections of ½ seconds and 1, 15, 30, 60 minutes.
- Transmitter range (integral antenna) of 1150’ (350 m) under ideal conditions.

The STUW750 and STUW751 are a high performance Universal input temperature transmitter featuring performance over a wide of temperature configurations and applications.

The SmartLine family is also fully tested and compliant with Experion® PKS providing the highest level of compatibility assurance and integration capabilities. SmartLine easily meets the most demanding application needs for Temperature measurement applications.

SmartLine Wireless Features

Local and over-the-air provisioning capability: All Honeywell wireless devices feature a secure method to join the local wireless network, also known as provisioning. SmartLine Wireless transmitters feature two methods to provision a transmitter onto the network which are either by using a handheld device to locally communicate through the IR interface or remotely using the over-the-air function. The over-the-air function is managed by the OneWireless gateway, Wireless Device Manager (WDM). In either method, the communication of secure, unique provisioning keys is one of the main factors to prevent against unintended access. Honeywell’s security keys are unique for each device from the factory, never made visible, always encrypted, and uniquely generated from the gateway that manages the deployed network.

Over-the-air firmware updates: Once joined as a member of your OneWireless network, the WDM can download new transmitter firmware releases to each SmartLine Wireless transmitter over the wireless network. Locating and accessing the transmitter locally is not required thus saving time and keeping your personnel in safe environments.

Mesh and non-mesh capability: All SmartLine Wireless transmitters can be configured to operate in either a mesh network or a star (non-mesh) network. The configuration is specific to each wireless transmitter and thus the network can consist of a mixture of meshing and non-meshing devices. Non-meshing is desirable for deterministic communications which is preferred for control.

Transmission power setting: To comply with local and regional requirements, SmartLine Wireless transmitters are set at the factory to the maximum transmission power setting allowed for the country of use.

Non-proprietary battery: Sourcing lithium thionyl chloride batteries is much simpler since SmartLine Wireless utilizes commercial off-the-shelf batteries. Please see the list of approved battery manufacturers later in this specification. Batteries are housed in an IS-approved battery compartment making battery changes safe and easy.

Backward compatibility: SmartLine Wireless transmitters can join existing OneWireless networks and interoperate with existing XYR 6000 wireless transmitters or other ISA100 Wireless compliant transmitters or networks.

OneWireless Network Features

The core of the Honeywell wireless solution is the OneWireless Network which consists a gateway, access point(s), and field routers.

The Wireless Device Manager (WDM) serves as the gateway function and in this role, manages the communication from the wireless field devices to the process control application. Typically, the WDM connects logically to the process control network (Level 2 or wireless DMZ). As the wireless network manager, the WDM provides easy access to the entire wireless network through a browser-based user interface. The Honeywell WDM can manage devices communicating over the ISA100 Wireless protocol and the Wireless HART™ protocol.

The ability to deploy redundant WDMs improves the reliability ensuring no loss of process data which is a requirement for control applications.

The Field Device Access Point (FDAP) serves in two roles in the OneWireless network infrastructure, which are: 1) access point, and 2) field router. As an access point, the FDAP directly connects to the WDM via Ethernet LAN cable. More than one access point is permitted and, when more than one is present, it ensures dual path for communications into the WDM from the field devices. As a field router, the FDAP located in the field would communicate to the FDAP acting as an access point. Using the FDAP as a router is more efficient than using field devices as routers since FDAPs are line powered devices whereas field devices are typically battery powered, and the FDAP offers greater range. The meshing capability of FDAPs allows flexibility in the setup of the wireless network to fit the requirements for wireless network performance, in terms of reliable communications, performance, and future growth. The choice of non-meshing network may be desirable for reduced communication latencies with a FDAP serving as a field router.

Wireless Specifications

Table 1

Parameter	Description
Wireless Communication	2,400 to 2,483.5 MHz (2.4 GHz) Industrial, Scientific and Medical (ISM) band DSSS - Direct Sequential Spread Spectrum per FCC 15.247 / IEEE 802.15.4 2006 Every data packet transmitted in either direction is verified (CRC check) and acknowledged by the receiving device. USA – FCC Certified Canada – IC Certified European Union – Radio Equipment Directive compliant.
DSSS RF Transmitter Power	NA Selection –100 mW (20.0 dBm) maximum EIRP including antenna for USA and Canadian locations. EU Selection – 63 mW (18.0 dBm) maximum EIRP including antenna per RTTE/ETSI for EU locations. Compliant to ETSI EN 300 328 wireless standard.
Data	PV Publish Cycle Time: Configurable as 0.5, 1, 5, 10, 30 seconds, plus 1, 15, 30, 60 minutes Rate: 250 Kbps.
Antennas	Integral – 4 dBi omnidirectional monopole (default selection). Remote – 8 dBi omnidirectional monopole with up to two 10 m cables and lightning surge arrester. Remote – 14 dBi directional parabolic with up to two 10 m cables and lightning surge arrester.
Signal Range	Nominal 350 m (1150 feet) between Field Transmitter and Infrastructure Unit (FDAP) when using 4 dBi Integral antenna with a clear line of sight*.

*Actual range will vary depending on antennas, cables and site topography.

Specifications

Operating Conditions – All Models

Table 2

Parameter	Reference Condition (at zero static)		Rated Condition		Operative Limits		Transportation and Storage	
	°C	°F	°C	°F	°C	°F	°C	°F
Ambient Temperature ¹	25 ±1	77 ±2	-40 to 85	-40 to 185	-40 to 85	-40 to 185	-40 to 85	-40 to 185
Ambient Temperature LCD Display visible range	25 ±1	77 ±2	-20 to 70	-4 to 158				
Humidity %RH	10 to 55		0 to 100		0 to 100		0 to 100	
Vibration	Maximum of 4g over 15 to 200Hz.							
Shock	Maximum of 40g.							
Power	Commercially available, non-proprietary 3.6V Lithium thionyl chloride (LiSOCI2) batteries, non-rechargeable, size D. Battery pack-only option is available. Approved list of the manufacturer models: <ol style="list-style-type: none"> 1. Xeno Energy XL-205F 2. Eagle Picher PT-2300H 3. Tadiran TL-5930/s 							
	24 VDC power option. For Non I.S. application: 16 to 28 VDC input range, max input current 100mA. For I.S. application: Barrier in accordance with the control drawing required, entity parameters 30V, 120mA, 0.9W.							

¹ The Ambient Limits shown are for Ordinary Non-Hazardous locations only. Refer to the Hazardous Locations Approvals section for the Ambient Limits when installed in Hazardous Locations.

Remote Antenna Cables

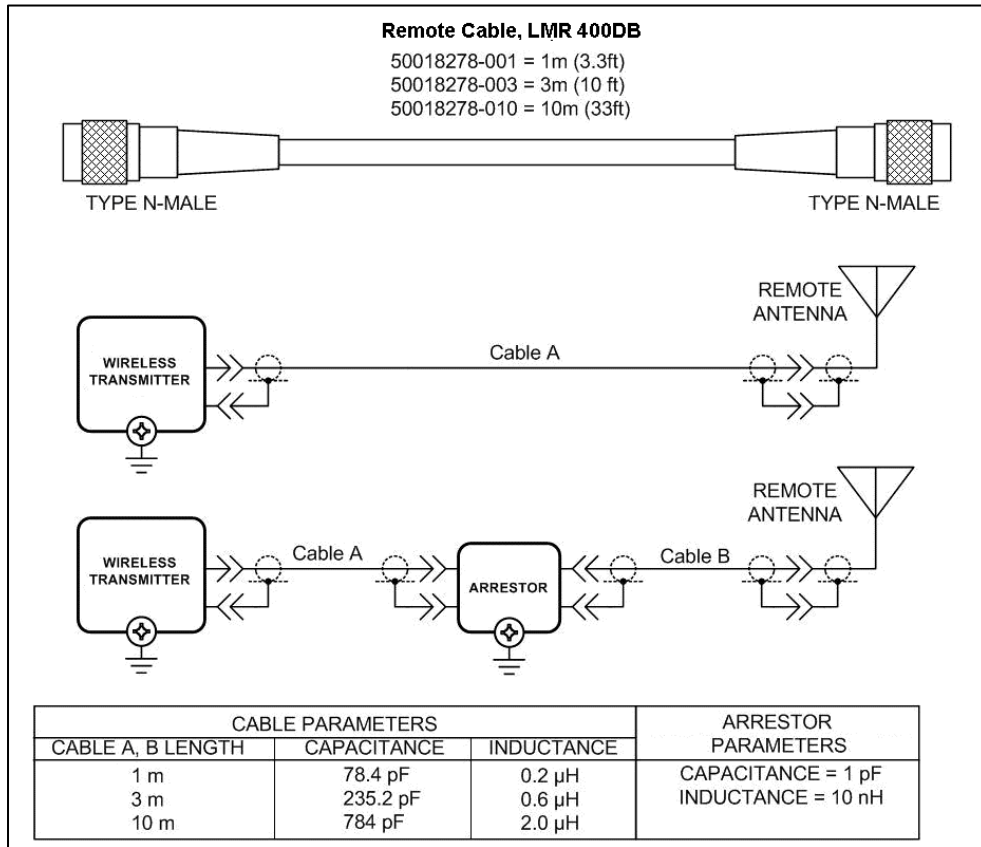

Remote Antennas

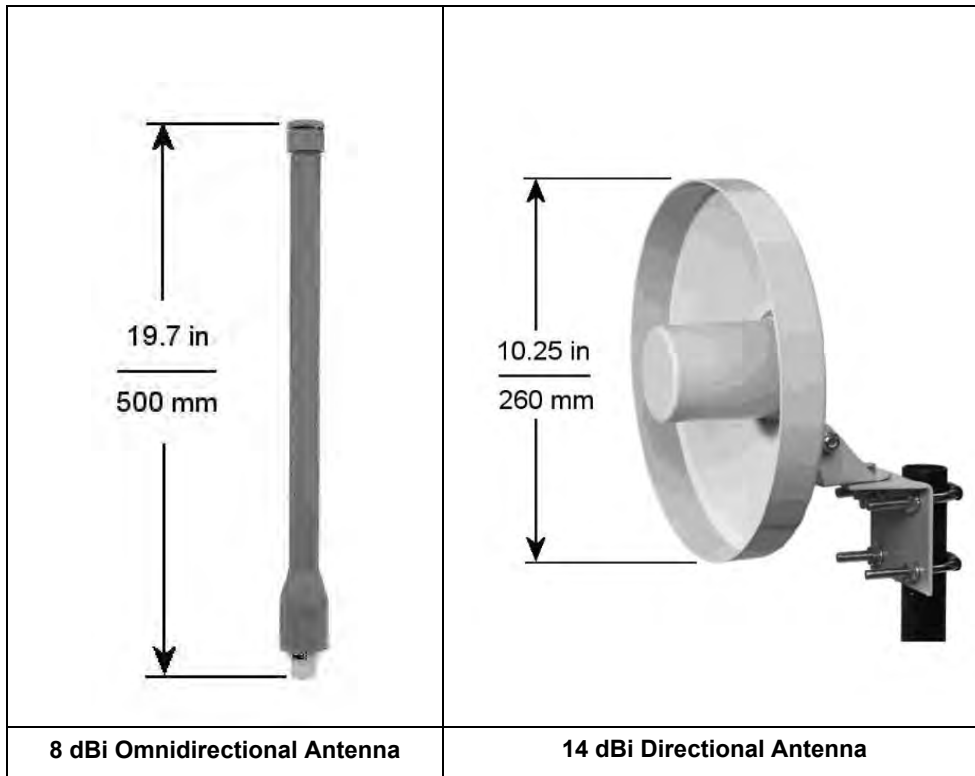

Performance Specifications

Performance under Rated Conditions*

Table 3

Parameter	Description
Accuracy *	±0.10% of range at reference conditions for T/C's, mV and HLAI inputs. ±0.30% of range for 2 Wire and DI resistance measurement.
Temperature Effects	±0.01% of full scale per °C for T/C's, mV and HLAI inputs. ±0.015% of full scale per °C for 2 Wire and DI resistance measurement.
Stability	±0.10% of URL per year.
Stray Rejection	Common Mode (50 or 60 Hz): 120 dB Normal Mode (50 or 60 Hz): 40 dB
Maximum Lead Wire Resistance	50 ohms/leg for all analog input types.
Discrete Input	Single SPST dry contacts. Maximum "ON" contact resistance of 200 Ohms *** Minimum "OFF" contact resistance of 300 Ohms Resistances must include all field wiring. Thresholds values are configurable.
Discrete Output	AC/DC Voltage Supply 30 V max Load current = 0.5 A max
Battery Life with Digital Output	50% Duty cycle - Approximately 1 year
4-20 mA Input Loop Resistance	max 50 Ohms (10 ohms resistor + signal diode)
Cold Junction Accuracy	±0.5 °C
Lightning Surge Arrester (Remote antenna only)	Frequency range: 0 – 3 GHz, 50 Ohms, VSWR = 1:1.3 Max, Insertion Loss = 0.4 dB Connectors Type N Female, Max, Gas Tube Element: 90 V ± 20%, Impulse Breakdown Voltage = 1,000 V ± 20%, Maximum Withstand Current = 5 KA.
Hazardous Location Certifications	See the Model Selection Guide on page 16.
Electromagnetic Compatibility	IEC 61326-1
Lightning Surge Arrester (Remote antenna only)	Frequency range: 0 – 3 GHz, 50 Ohms, VSWR = 1:1.3 Max, Insertion Loss = 0.4 dB Connectors Type N Female, Max, Gas Tube Element: 90 V ± 20%, Impulse Breakdown Voltage = 1,000 V ± 20%, Maximum Withstand Current = 5 KA.
CE Conformity	These transmitters are in conformity with the Radio Equipment Directive, ETSI EN 300 328 V2.1.1 including EMC standard EN61326-1 2013.

*Field Calibration available for increased accuracy applications.

**Performance specifications are based on reference conditions of 25°C (77°F), 10 to 55% RH.

Physical Specifications

Table 4

Parameter	Description
Mounting Bracket	Carbon Steel (zinc-plated) or Stainless Steel angle bracket or flat bracket available.
Electronic Housing	Epoxy-Polyester hybrid paint. Low Copper-Aluminum with 1/2" NPT or M20 conduit connections. Meets NEMA 4X (hosedown and corrosion resistant), IP 66/67 (hosedown and submersible to 1m).
Stainless Steel Housing (option)	316 SS or Grade CF8M, the casting equivalent of 316 SS with M20 or 1/2" NPT conduit connections. If ordered with the Remote Antenna options, the antenna parts are not SS or Marine type cables; the integral antenna uses SS parts.
Process Connections	1/4-inch NPT; 1/2-inch NPT with adapter. Process heads meet DIN 19213 requirements.
Mounting	Can be mounted in virtually any position using the standard mounting bracket. Mounting should result in the antenna being vertically oriented. Bracket is designed to mount on 2-inch (50 mm) vertical or horizontal pipe. See Figure 2 and 3.
Dimensions	See Figure 4, Figure 5 and Figure 6.
Net Weight	Approximately 9 pounds (4.1 Kg).

¹ Add 8.0 pounds (3.6 kg) to any model equipped with stainless steel housing option (Model Selection Guide Table IV Selection M or N).

STUW750 ISA100.11a Compliant Inputs

Any combination of sensor type inputs is allowed. The input channels can be configured for the following input types by using the OneWireless User Interface with the corresponding device descriptor file:

Table 5

Channel 1	Channel 2	Channel 3
T/C, mV, mA, DI, 2W Resistance	T/C, mV, mA, DI, 2W Resistance	T/C, mV, mA, DI, 2W Resistance

STUW751 ISA100.11a Compliant Inputs

Any combination of sensor type inputs is allowed. The input channels can be configured for the following input types by using the OneWireless User Interface with the corresponding device descriptor file:

Table 6

Channel 1	Channel 2	Channel 3
T/C, mV, mA, DI, 2W Resistance	T/C, mV, mA, DI, 2W Resistance	DO only

The transmitter measures the analog signal from temperature sensors, discrete inputs, millivolt values or ohm values and transmits a digital output signal proportional to the measured value for direct digital communications with systems.

The discrete input channels support voltage-free floating contacts. Maximum ON contact resistance is 200 ohms. Minimum OFF contact resistance is 300 ohms. Discrete Input threshold values are user configurable.

The Process Variable (PV) is available for monitoring and alarm purposes. The cold junction temperature is also available for monitoring. Available PV update rates are 1, 5, 10, or 30 seconds, plus new selections of 1/2 sec (Refer User Manual for applicable conditions) and 1, 15, 30, 60 minutes and are set using the Wireless Builder. Slower update rates extend battery life.

Input Types and Ranges

Table 7

Input Type	Range Deg. F	Range Deg. C
Type B T/C	0 to 3300	-18 to +1816
Type E T/C	-454 to +1832	-270 to +1000
Type J T/C	0 to 1600	-18 to + 871
Type K T/C	0 to 2400	-18 to +1816
Type N T/C	0 to 2372	-18 to +1300
Type R T/C	0 to 3100	-18 to +1704
Type S T/C	0 to 3100	-18 to +1704
Type T T/C	-300 to +700	-184 to +371
Millivolts	0 to 10 mV 0 to 50 mV 0 to 100 mV	
2W Resistance (Ohms)	0 to 100Ω 0 to 200Ω 0 to 500Ω 0 to 1000Ω	
Discrete input	200 Ohms Max ON Contact Resistance (user configurable) 300 Ohms Min OFF Contact Resistance (user configurable)	
High Level Analog Input Current Ranges	0 to 20 mA / 4-20 mA	

STUW750 UNIVERSAL IO TRANSMITTER CONNECTIONS

HLAI (0/4-20mA) or T/C or mV or DI or 2 Wire Resistance

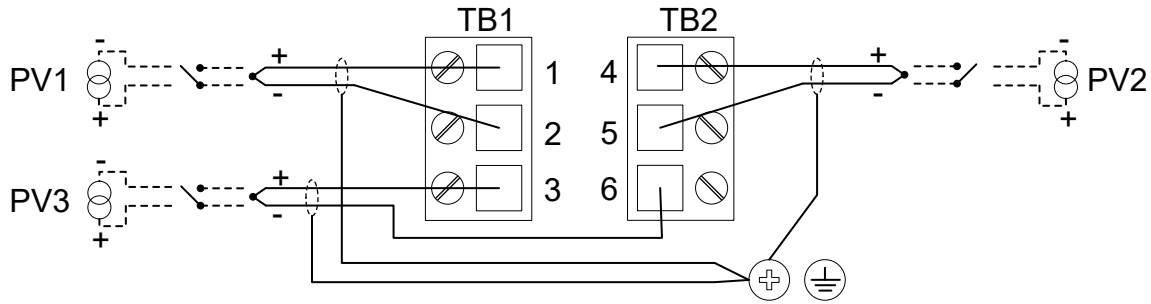

STUW751 UNIVERSAL IO TRANSMITTER CONNECTIONS

HLAI (0/4-20mA) or T/C or mV or DI or 2 Wire Resistance

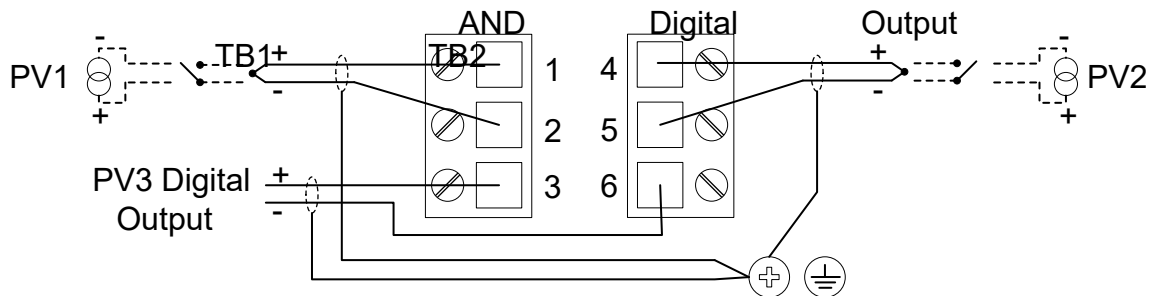

Mounting and Dimensions

Reference Dimensions:

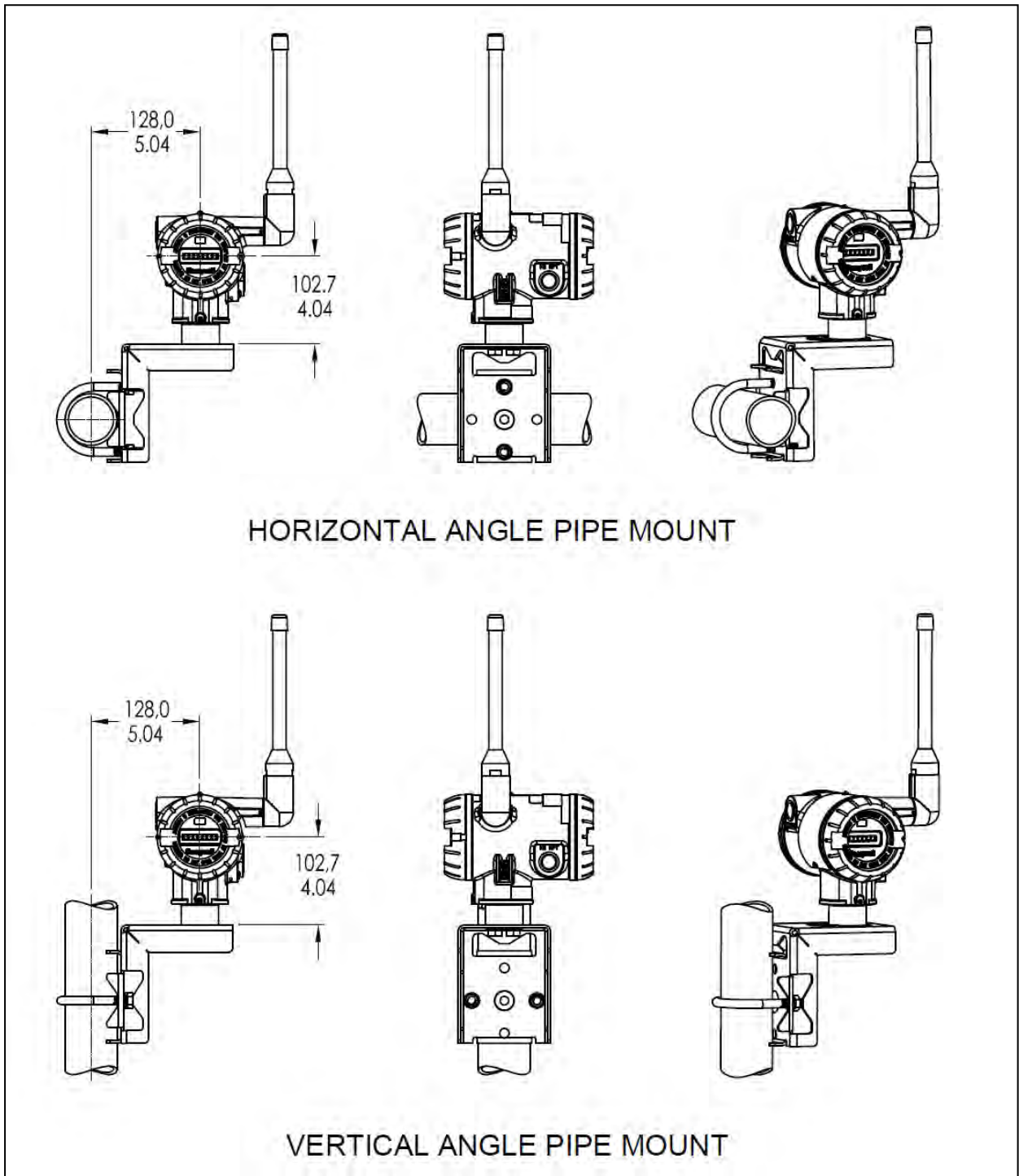

Figure 2 — Examples of typical mounting positions

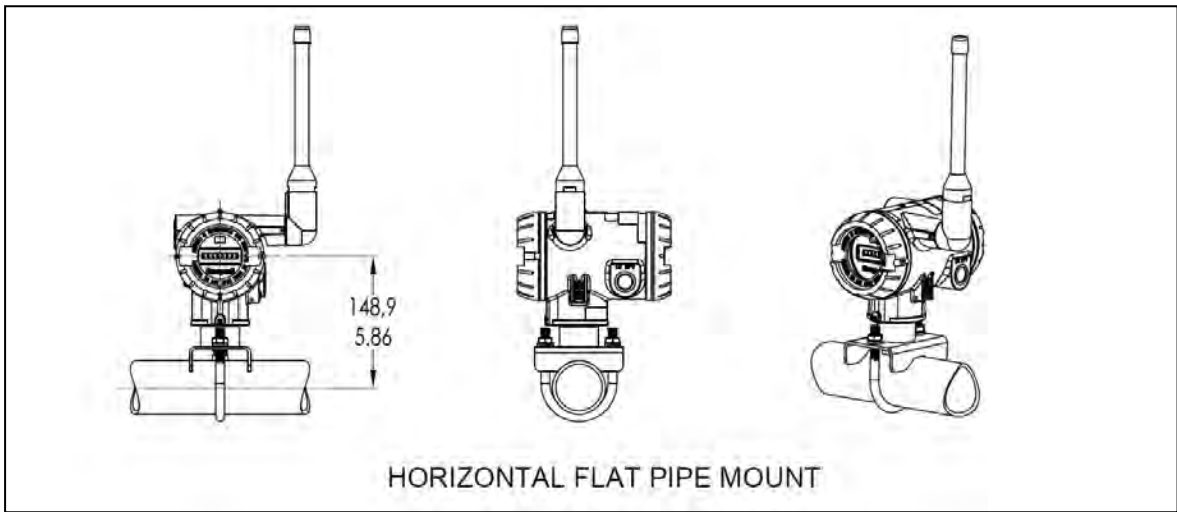

Figure 3 - Examples of typical mounting positions

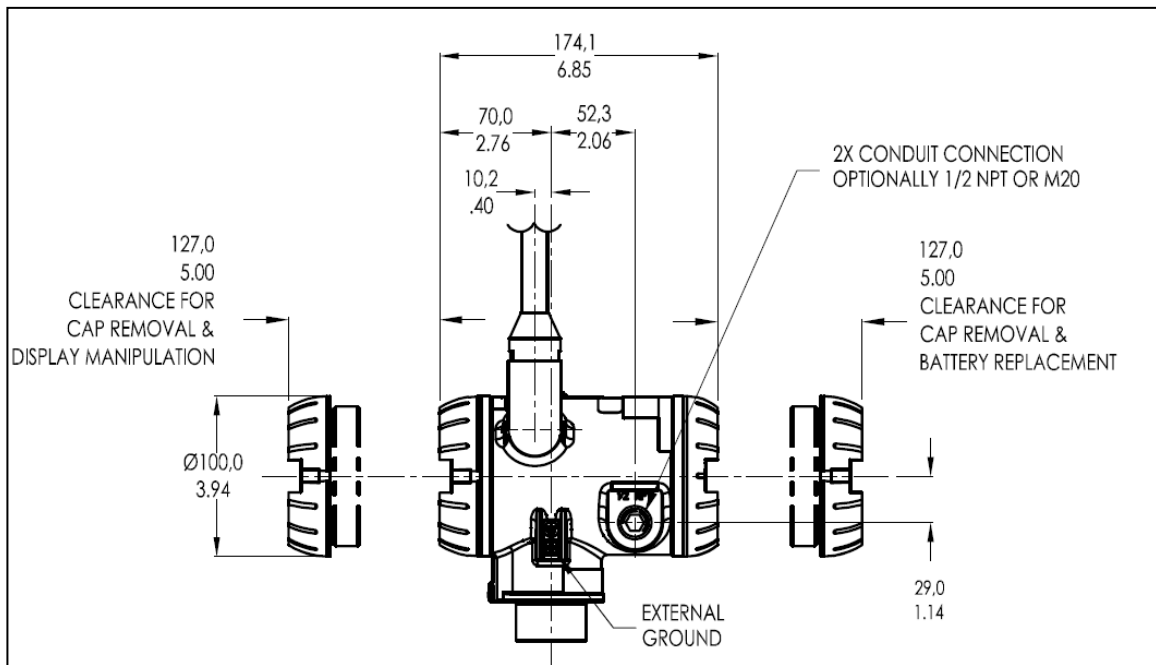

Figure 4 - STUW750 Informational and dimensional drawing

По вопросам продаж и поддержки обращайтесь:

Алматы (7273)495-231
Ангарск (3955)60-70-56
Архангельск (8182)63-90-72
Астрахань (8512)99-46-04
Барнаул (3852)73-04-60
Белгород (4722)40-23-64
Благовещенск (4162)22-76-07
Брянск (4832)59-03-52
Владивосток (423)249-28-31
Владикавказ (8672)28-90-48
Владимир (4922)49-43-18
Волгоград (844)278-03-48
Вологда (8172)26-41-59
Воронеж (473)204-51-73
Екатеринбург (343)384-55-89
Иваново (4932)77-34-06
Ижевск (3412)26-03-58
Иркутск (395)279-98-46
Казань (843)206-01-48

Калининград (4012)72-03-81
Калуга (4842)92-23-67
Кемерово (3842)65-04-62
Киров (8332)68-02-04
Коломна (4966)23-41-49
Кострома (4942)77-07-48
Краснодар (861)203-40-90
Красноярск (391)204-63-61
Курган (3522)50-90-47
Курск (4712)77-13-04
Липецк (4742)52-20-81
Магнитогорск (3519)55-03-13
Москва (495)268-04-70
Мурманск (8152)59-64-93
Набережные Челны (8552)20-53-41
Нижний Новгород (831)429-08-12
Новокузнецк (3843)20-46-81
Новосибирск (383)227-86-73
Ноябрьск(3496)41-32-12

Омск (3812)21-46-40
Орел (4862)44-53-42
Оренбург (3532)37-68-04
Пенза (8412)22-31-16
Пермь (342)205-81-47
Петрозаводск (8142)55-98-37
Псков (8112)59-10-37
Ростов-на-Дону (863)308-18-15
Рязань (4912)46-61-64
Самара (846)206-03-16
Санкт-Петербург (812)309-46-40
Саранск (8342)22-96-24
Саратов (845)249-38-78
Севастополь (8692)22-31-93
Симферополь (3652)67-13-56
Смоленск (4812)29-41-54
Сочи (862)225-72-31
Ставрополь (8652)20-65-13
Сургут (3462)77-98-35

Сыктывкар (8212)25-95-17
Тамбов (4752)50-40-97
Тверь (4822)63-31-35
Тольятти (8482)63-91-07
Томск (3822)98-41-53
Тула (4872)33-79-87
Тюмень (3452)66-21-18
Улан-Удэ (3012)59-97-51
Ульяновск (8422)24-23-59
Уфа (347)229-48-12
Хабаровск (4212)92-98-04
Чебоксары (8352)28-53-07
Челябинск (351)202-03-61
Череповец (8202)49-02-64
Чита (3022)38-34-83
Якутск (4112)23-90-97
Ярославль (4852)69-52-93

Россия +7(495)268-04-70

Казахстан +7(7172)727-132

Киргизия +996(312)96-26-47

сайт: www.honeywell.nt-rt.ru || эл. почта: hwn@nt-rt.ru