

По вопросам продаж и поддержки обращайтесь:

Алматы (7273)495-231
Ангарск (3955)60-70-56
Архангельск (8182)63-90-72
Астрахань (8512)99-46-04
Барнаул (3852)73-04-60
Белгород (4722)40-23-64
Благовещенск (4162)22-76-07
Брянск (4832)59-03-52
Владивосток (423)249-28-31
Владикавказ (8672)28-90-48
Владимир (4922)49-43-18
Волгоград (844)278-03-48
Вологда (8172)26-41-59
Воронеж (473)204-51-73
Екатеринбург (343)384-55-89
Иваново (4932)77-34-06
Ижевск (3412)26-03-58
Иркутск (395)279-98-46
Казань (843)206-01-48

Калининград (4012)72-03-81
Калуга (4842)92-23-67
Кемерово (3842)65-04-62
Киров (8332)68-02-04
Коломна (4966)23-41-49
Кострома (4942)77-07-48
Краснодар (861)203-40-90
Красноярск (391)204-63-61
Курган (3522)50-90-47
Курск (4712)77-13-04
Липецк (4742)52-20-81
Магнитогорск (3519)55-03-13
Москва (495)268-04-70
Мурманск (8152)59-64-93
Набережные Челны (8552)20-53-41
Нижний Новгород (831)429-08-12
Новокузнецк (3843)20-46-81
Новосибирск (383)227-86-73
Ноябрьск(3496)41-32-12

Омск (3812)21-46-40
Орел (4862)44-53-42
Оренбург (3532)37-68-04
Пенза (8412)22-31-16
Пермь (342)205-81-47
Петрозаводск (8142)55-98-37
Псков (8112)59-10-37
Ростов-на-Дону (863)308-18-15
Рязань (4912)46-61-64
Самара (846)206-03-16
Санкт-Петербург (812)309-46-40
Саранск (8342)22-96-24
Саратов (845)249-38-78
Севастополь (8692)22-31-93
Симферополь (3652)67-13-56
Смоленск (4812)29-41-54
Сочи (862)225-72-31
Ставрополь (8652)20-65-13
Сургут (3462)77-98-35

Сыктывкар (8212)25-95-17
Тамбов (4752)50-40-97
Тверь (4822)63-31-35
Тольятти (8482)63-91-07
Томск (3822)98-41-53
Тула (4872)33-79-87
Тюмень (3452)66-21-18
Улан-Удэ (3012)59-97-51
Ульяновск (8422)24-23-59
Уфа (347)229-48-12
Хабаровск (4212)92-98-04
Чебоксары (8352)28-53-07
Челябинск (351)202-03-61
Череповец (8202)49-02-64
Чита (3022)38-34-83
Якутск (4112)23-90-97
Ярославль (4852)69-52-93

Россия +7(495)268-04-70

Казахстан +7(7172)727-132

Киргизия +996(312)96-26-47

сайт: www.honeywell.nt-rt.ru || эл. почта: hwn@nt-rt.ru

ТЕРМОПРЕОБРАЗОВАТЕЛИ

Технические характеристики

на TD4A, TD5A



FEATURES

- Interchangeable without sensor-to-sensor recalibration
- Very small thermal mass for fast response
- Air or liquid temperature sensing
- Linear temperature sensitivity
- Proven thin film processing reliability
- Low cost
- Long term stability
- 2000 ohms nominal resistance at 20°C

TYPICAL APPLICATIONS

- HVAC – room, duct and refrigerant temperature
- Motors – overload protection
- Electronic circuits – semiconductor protection
- Process control – temperature regulation
- Automotive – air or oil temperature
- Appliances – cooking temperature

GENERAL INFORMATION

TD Series temperature sensors from MICRO SWITCH respond rapidly to temperature changes, and are accurate to $\pm 0.7^\circ\text{C}$ at 20°C —completely interchangeable without recalibration. They are RTD (resistance temperature detector) sensors, and provide $8 \Omega/^\circ\text{C}$ sensitivity, with inherently near linear outputs.

The sensing element is a silicon chip, 0.040×0.050 " with a thin film resistive network pattern. The chips are individually laser trimmed to provide 2000 ohms nominal resistance at room temperature (20°C), accurate to $\pm 0.7^\circ\text{C}$. Maximum error over the entire operating range of -40 to $+150^\circ\text{C}$ (-40 to $+302^\circ\text{F}$) is $\pm 2.5^\circ\text{C}$. This extremely accurate trimming provides true sensor-to-sensor interchangeability without recalibration of the user circuit.

TD4A Liquid temperature sensor TD4A

liquid temperature sensor is a two-terminal threaded anodized aluminum housing. The environmentally sealed liquid temperature sensors are designed for simplicity of installation, such as in the side of a truck. TD4A sensors are not designed for total immersion. Typical response time (for one time constant) is 4 minutes in still air and 15 seconds in still water (unmounted position). The temperature rise is $0.12^\circ\text{C}/\text{milliwatt}$ suspended by leads in still air, and $0.08^\circ\text{C}/\text{milliwatt}$ when mounted on 1 square foot 0.25 " thick aluminum foil.

TD5A Miniature temperature sensor

The TD5A is a subminiature temperature sensor with three leads (center not connected). It has response times of 11.0 seconds and a temperature rise of $.23^\circ\text{C}$ per milliwatt in still air.

TD4A

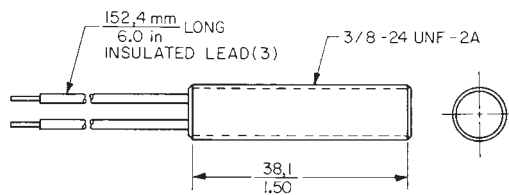

TD ORDER GUIDE

Catalog Listing	Description
TD4A	Liquid temperature sensor, 1.5° threaded (3/8-24 UNF-2A) anodized aluminum housing, two six inch black insulated leads
TD5A	Subminiature package, low cost, fast response time (TO-92)

MOUNTING DIMENSIONS (for reference only)

TD5A

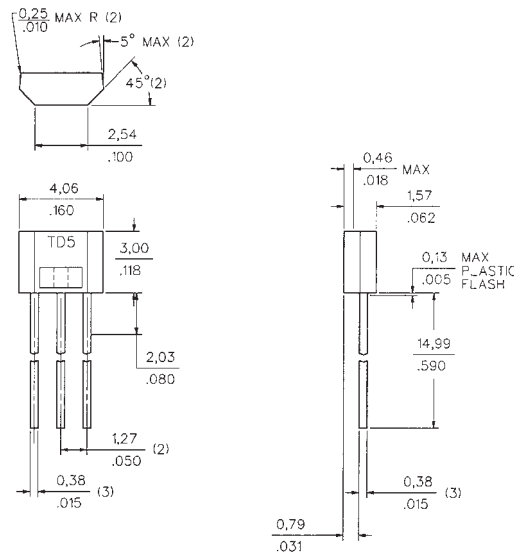

Center lead
not connected

ABSOLUTE MAXIMUM RATINGS

Operating temperature range	-40 to +150°C (-40 to +302°F)
Storage temperature range	-55 to 165°C (-67 to +338°F)
Voltage	10 VDC Continuous (24 hours)

INTERCHANGEABILITY (with 100 mA maximum current)

Temperature	Resistance (Ohms)	Temperature	Resistance (Ohms)
-40°C (-40°F)	1584 ± 12 (1.9°C)	+60°C (140°F)	2314 ± 9 (1.1°C)
-30°C (-22°F)	1649 ± 11 (1.7°C)	+70°C (158°F)	2397 ± 10 (1.2°C)
-20°C (-4°F)	1715 ± 10 (1.5°C)	+80°C (176°F)	2482 ± 12 (1.4°C)
-10°C (14°F)	1784 ± 9 (1.3°C)	+90°C (194°F)	2569 ± 14 (1.6°C)
0°C (32°F)	1854 ± 8 (1.1°C)	+100°C (212°F)	2658 ± 16 (1.8°C)
+10°C (50°F)	1926 ± 6 (0.8°C)	+110°C (230°F)	2748 ± 18 (2.0°C)
+20°C (68°F)	2000 ± 5 (0.7°C)	+120°C (248°F)	2840 ± 19 (2.0°C)
+30°C (86°F)	2076 ± 5 (0.7°C)	+130°C (266°F)	2934 ± 21 (2.2°C)
+40°C (104°F)	2153 ± 6 (0.8°C)	+140°C (284°F)	3030 ± 23 (2.4°C)
+50°C (122°F)	2233 ± 7 (0.9°C)	+150°C (302°F)	3128 ± 25 (2.5°C)

It is recommended that resistance measurements be made at 100 μA or less to minimize internal heating of the sensor. Measurements at currents up to 1mA will not damage the sensor, but the resistance characteristics should be adjusted for internal heating.

Equation for computing resistance:

$$R_T = R_0 + (3.84 \times 10^{-3} \times R_0 \times T) + (4.94 \times 10^{-6} \times R_0 \times T^2)$$

R_T = Resistance at temperature T

R_0 = Resistance at 0°C

T = Temperature in °C

Figure 2
Linear Output Voltage Circuit

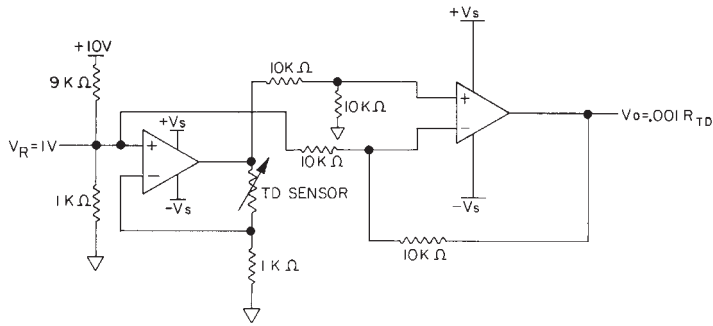
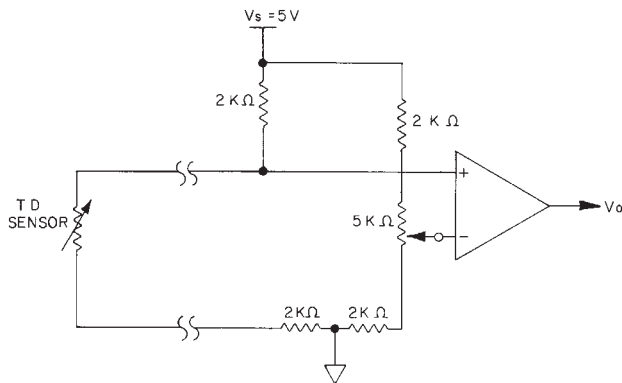

Figure 3
Adjustable Point (Comparator) Interface



Linearity

±2% (-25 to 85°C)

±3% (-40 to 150°C)

TD sensors can be linearized to within ±0.2%.

Repeatability

±1 Ω

Figure 1
TD Series Resistance vs Temperature

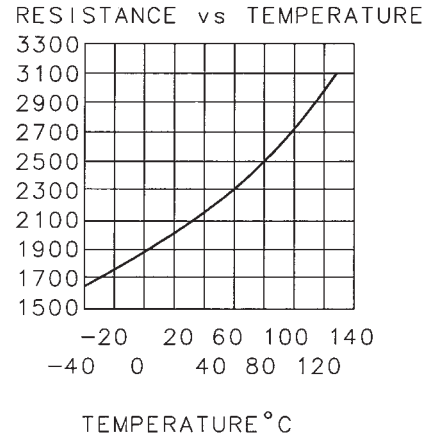

ELECTRICAL INTERFACING

The high nominal resistance, positive temperature coefficient and linear sensitivity characteristics of the TD Series temperature sensors simplifies the task of de-signing the electrical interface.

Figure 2 is a simple circuit that can be used to linea-rize the voltage output to within 0.2% or a±0.4°C error over a range of -40° to+150°C (-40° to +302° F).

In some applications, it may be desirable to detect one particular temperature. Figure 3 illustrates one way this can be accomplished. In the comparator circuit shown, the potentiometer can be adjusted to correspond to the desired temperature.

По вопросам продаж и поддержки обращайтесь:

Алматы (7273)495-231
Ангарск (3955)60-70-56
Архангельск (8182)63-90-72
Астрахань (8512)99-46-04
Барнаул (3852)73-04-60
Белгород (4722)40-23-64
Благовещенск (4162)22-76-07
Брянск (4832)59-03-52
Владивосток (423)249-28-31
Владикавказ (8672)28-90-48
Владимир (4922)49-43-18
Волгоград (844)278-03-48
Вологда (8172)26-41-59
Воронеж (473)204-51-73
Екатеринбург (343)384-55-89
Иваново (4932)77-34-06
Ижевск (3412)26-03-58
Иркутск (395)279-98-46
Казань (843)206-01-48

Калининград (4012)72-03-81
Калуга (4842)92-23-67
Кемерово (3842)65-04-62
Киров (8332)68-02-04
Коломна (4966)23-41-49
Кострома (4942)77-07-48
Краснодар (861)203-40-90
Красноярск (391)204-63-61
Курган (3522)50-90-47
Курск (4712)77-13-04
Липецк (4742)52-20-81
Магнитогорск (3519)55-03-13
Москва (495)268-04-70
Мурманск (8152)59-64-93
Набережные Челны (8552)20-53-41
Нижний Новгород (831)429-08-12
Новокузнецк (3843)20-46-81
Новосибирск (383)227-86-73
Ноябрьск (3496)41-32-12

Омск (3812)21-46-40
Орел (4862)44-53-42
Оренбург (3532)37-68-04
Пенза (8412)22-31-16
Пермь (342)205-81-47
Петрозаводск (8142)55-98-37
Псков (8112)59-10-37
Ростов-на-Дону (863)308-18-15
Рязань (4912)46-61-64
Самара (846)206-03-16
Санкт-Петербург (812)309-46-40
Саранск (8342)22-96-24
Саратов (845)249-38-78
Севастополь (8692)22-31-93
Симферополь (3652)67-13-56
Смоленск (4812)29-41-54
Сочи (862)225-72-31
Ставрополь (8652)20-65-13
Сургут (3462)77-98-35

Сыктывкар (8212)25-95-17
Тамбов (4752)50-40-97
Тверь (4822)63-31-35
Тольятти (8482)63-91-07
Томск (3822)98-41-53
Тула (4872)33-79-87
Тюмень (3452)66-21-18
Улан-Удэ (3012)59-97-51
Ульяновск (8422)24-23-59
Уфа (347)229-48-12
Хабаровск (4212)92-98-04
Чебоксары (8352)28-53-07
Челябинск (351)202-03-61
Череповец (8202)49-02-64
Чита (3022)38-34-83
Якутск (4112)23-90-97
Ярославль (4852)69-52-93

Россия +7(495)268-04-70

Казахстан +7(7172)727-132

Киргизия +996(312)96-26-47

сайт: www.honeywell.nt-rt.ru || эл. почта: hwn@nt-rt.ru