

**MagneW 3000 *PLUS*
Smart Electromagnetic
Flowmeter Specification
and Application Guide**

По вопросам продаж и поддержки обращайтесь:
Астана +7(7172)727-132, Волгоград (844)278-03-48, Воронеж (473)204-51-73, Екатеринбург (343)384-55-89,
Казань (843)206-01-48, Краснодар (861)203-40-90, Красноярск (391)204-63-61, Москва (495)268-04-70,
Нижний Новгород (831)429-08-12, Новосибирск (383)227-86-73, Ростов-на-Дону (863)308-18-15,
Самара (846)206-03-16, Санкт-Петербург (812)309-46-40, Саратов (845)249-38-78, Уфа (347)229-48-12
Единый адрес: hwn@nt-rt.ru
www.honeywell.nt-rt.ru

Table of Contents

INTRODUCTION	1
COMPONENTS	1
PRINCIPLE OF OPERATION	2
HARDWARE CONFIGURATION	2
FEATURES	3
DETECTOR	3
CONVERTER	3
OPERATOR INTERFACE	4
DIAGNOSTICS	5
COMMUNICATIONS SUMMARY	5
SUMMARY OF MAGNEW 3000 PLUS FEATURES	6
WIRING SUMMARY	7
Electrical Connection Considerations	8
Cable Types.....	8
Laying of Cables.....	8
Cable Lengths.....	8
Grounding.....	8
Terminal Connections.....	9
Cabling for Remote Detector/Converter	10
RANGING FUNCTION	11
SELECTION OF CORROSION RESISTANT MATERIALS	12
APPLICATION DATA WORKSHEET	13
INSTALLATION PLANNING CONSIDERATIONS	14
Environmental Conditions	14
Fluid to be Measured	15
Measured Liquid Flow Conditions.....	15
Detector Location in Piping	16
Clearance for Maintenance.....	18
SPECIFICATIONS	19
Performance	19
Design.....	19
Environmental and Operating Conditions.....	23
DIMENSIONS 25	
ORDERING DATA AND SPECIAL INSTRUCTIONS	36

Table of Contents

MODEL SELECTION GUIDES

MagneW 3000 PLUS Integral Converter and MGG18D Wafer Style Detector, Size 2.5-200mm.....	36-KI-16-24
MagneW 3000 PLUS Integral Converter and MGG18F Flange Style Detector, Size 15-200mm.....	36-KI-16-25
MagneW 3000 PLUS Remote Converter	36-KI-16-26
MagneW 3000 PLUS Remote Detector Wafer Type, Size 2.5-200mm	36-KI-16-29
MagneW 3000 PLUS Remote Detector Flange Type, Size 25-400mm.....	36-KI-16-30
MagneW 3000 PLUS Remote Detector Wafer Type, Size 2.5-200mm	36-KI-16-31
MagneW 3000 PLUS Remote Detector Flange Type, Size 25-600mm.....	36-KI-16-32
MagneW 3000 PLUS Submersible Detector Wafer Type, Size 15-200mm	36-KI-16-33
MagneW 3000 PLUS Submersible Remote Detector Flange Type, Size 25-600mm.....	36-KI-16-34
MagneW 3000 PLUS Cables.....	36-KI-16-35
MAGNEW 3000 PLUS APPLICATION DATA SHEET.....	36-KI-08-01

Figures and Tables

Figure 1	MagneW 3000 PLUS Components.....	1
Figure 2	Principle of Operation.....	2
Figure 3	Typical SFC Connection to the 4 to 20 mA Loop.....	4
Figure 4	Typical SFC Prompts.....	4
Figure 5	Digital Operator Panel Display (configured for % flow range).....	4
Figure 6	MagneW 3000 PLUS Communications Hierarchy for TPS.....	5
Figure 7	Overview of MagneW 3000 PLUS Wiring Requirements	7
Figure 8	Typical Wiring Connections for the MagneW 3000 PLUS Remote and Integral Flowmeters.....	9
Figure 9	Cable Length Versus Fluid Conductivity.....	10
Figure 10	Direct Direction, Automatic Dual Range Transfer Hysteresis.....	11
Figure 11	Direct/Reverse Transfer Hysteresis.....	11
Figure 12	Wall Mounting Dimensions	25
Figure 13	2-inch Pipe Mounting Dimensions	26
Figure 14	Dimensions for Integral Model—Refer to Table 8.....	27
Figure 15	Union Joint Dimensions – 2.5 mm to 15 mm (0.1 in. to 0.6 in.).....	28
Figure 16	Hose Joint Dimensions – 2.5 mm to 15 mm (0.1 in. to 0.6 in.).....	29
Figure 17	IDF/Tri-Clamp Dimensions – 2.5 mm to 15 mm (0.1 in. to 0.6 in.).....	30
Figure 18	Wafer Dimensions – 2.5 mm to 15 mm (0.1 in. to 0.6 in.) and 25 mm to 200 mm (1 in. to 7.9 in.)—Refer to Table 8.....	31
Figure 19	Flange Dimensions – 25 mm (1 in.).....	33
Figure 20	Flange Dimensions – 40 mm to 140 mm (1.6 in. to 3.9 in.) and 150 mm to 600 mm (5.9 in. to 23.6 in.)—Refer to Table 9.....	34
Table 1	Available Models.....	3
Table 2	Summary of Major MagneW 3000 PLUS Features.....	6
Table 3	Summary of Range Function Options.....	11
Table 4	Characteristics of Wet Contact Materials.....	12
Table 5	Summary of Installation Considerations.....	14
Table 6	Specifications for MagneW 3000 PLUS	19
Table 7	Minimum and Maximum Ranges.....	24
Table 8	Dimensions for Figures 14 and 18.....	32
Table 9	Dimensions for Figure 20.....	35

Introduction

The MagneW 3000 **PLUS** electromagnetic flowmeter consists of a detector/converter combination that operates on the principles of Faraday's Law. Based on Honeywell's proven MagneW 3000 flow measurement technologies, the **PLUS** detectors offer expanded flow rate and process measurement capabilities when used with the new range of **PLUS** converters.

The MagneW 3000 **PLUS** offers

- a wide range of wafers and flanges,
- IDF and Tri-Clamp couplings,
- local data setting device,
- batch control with preset counter trip,
- automatic dual-range switchover with reverse flow,
- high and low alarm settings,
- continuous self-diagnostics, and
- remote communication with SFC®.

The MagneW 3000 **PLUS** is part of the **TotalPlant®** Solution (TPS) system. TPS is the evolution of TDC 3000®^X.

Components

As shown in Figure 1, the MagneW 3000 **PLUS** flowmeter includes a detector and converter available in an integral-type or a remote-type configuration.

With an integral-type configuration, the converter mounts directly onto the detector.

With a remote-type configuration, the detector is connected by cables to the converter which can be mounted up to 300 meters (984 feet) away, depending on the application.

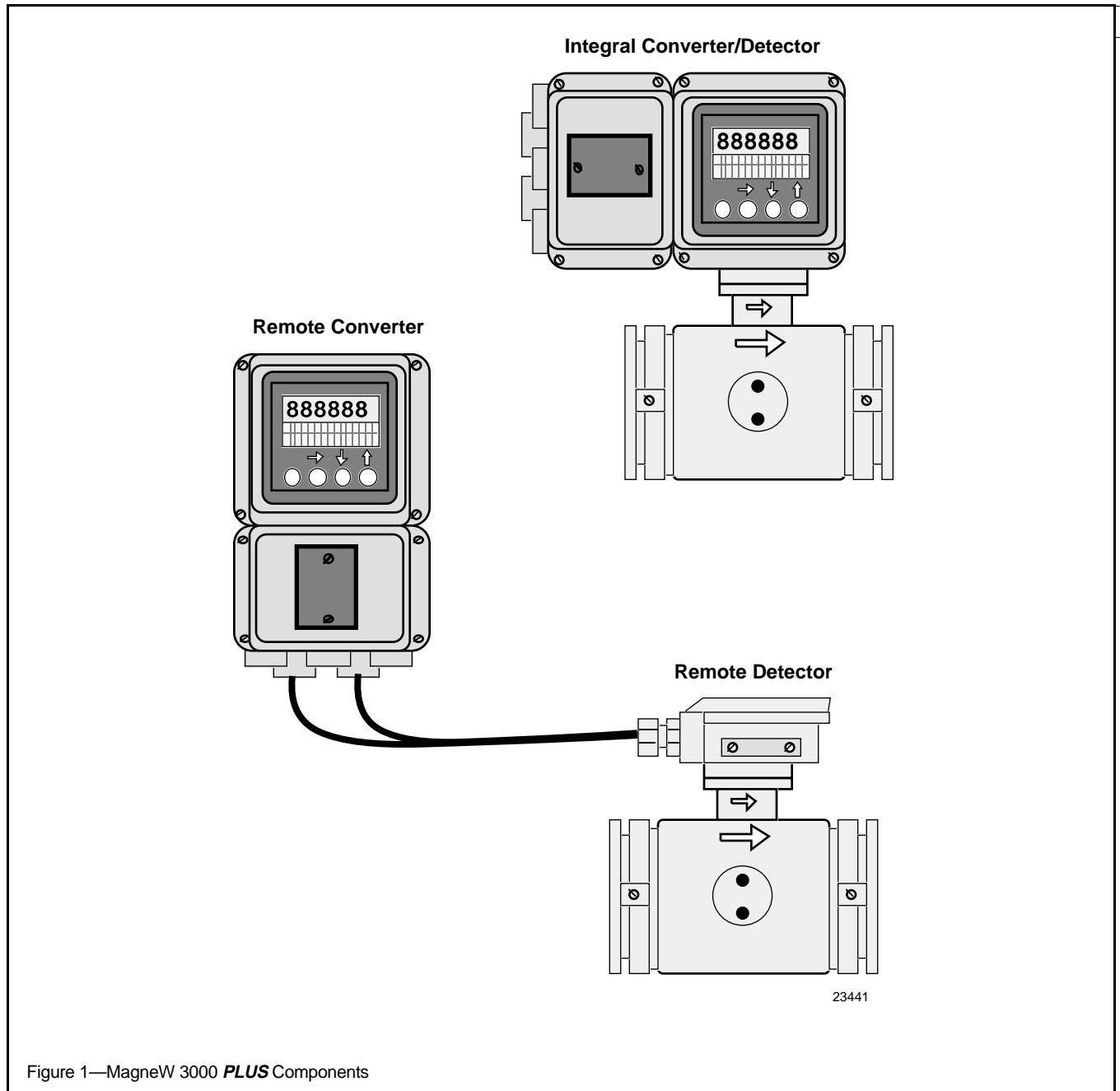

Figure 1—MagneW 3000 **PLUS** Components

Principle of Operation

The MagneW 3000 **PLUS** flowmeter's operating principle is based on Faraday's Law: *The voltage induced across any conductor, as it moves at right angles through a magnetic field, is proportional to the conductor's velocity.*

The detector fits on the pipe and measures the flow. The detector's excitation coils receive power from the converter. These coils create a magnetic field at a right angle to the flow direction.

As the conductive liquid flows through this magnetic field, a voltage which is proportional to the liquid flow velocity is produced across the electrodes. The detector sends these voltage signals to the converter. Refer to Figure 2.

The converter, which holds the circuitry that calculates and displays the flow data, converts the detector signals into outputs for recording and control instrumentation.

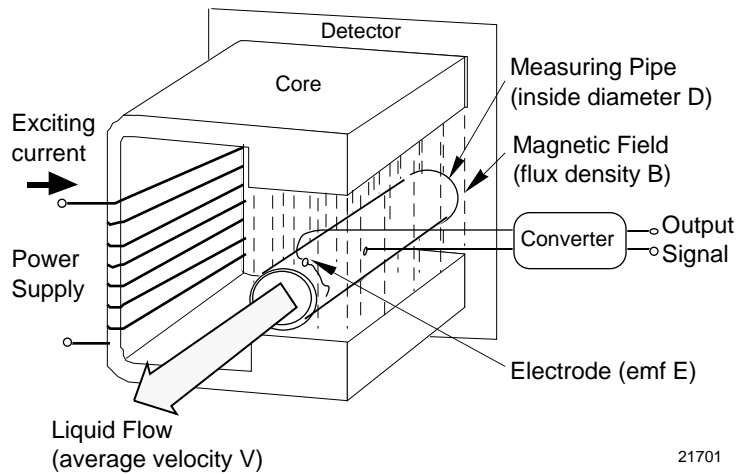

Figure 2—Principle of Operation

The relationship between the liquid flow velocity and the voltage is expressed in Faraday's formula:

E is proportional to $V \times B \times D$

where:

E = Induced Electromagnetic Voltage

Voltage generated by the flow of the conductive liquid through the magnetic field of the flowmeter.

V = Average Flow Velocity (m/s)

The average velocity of the liquid through the cross section of the flowmeter.

B = Magnetic Flux Density

The strength of the magnetic field generated by the field coils.

D = Inside Diameter of the Pipe

The distance between the electrodes which detect the signal voltage (E) that is generated.

This means that the voltage (E) depends on the average flow velocity (V), the magnetic flux density (B), and the inside diameter of the pipe (D).

Hardware Configuration

The MagneW 3000 **PLUS** flowmeter is available as either:

- an integral unit—converter mounted on detector, or
- a remote converter/remote detector.

The detector is mounted to the process piping, using one of the following types of connections:

- wafer,
- flange,
- union,
- hose, or
- IDF or Tri-clamp.

The type of connection used is dependent upon diameter size and the application. Where applicable, gaskets are supplied unless the grounding rings are made of SUS material.

If using the remote converter/remote detector combination, either a wall- or pipe-mounting kit for the converter and cables to connect the converter and detector are needed.

Features

Liquid crystal display with backlighting (optional)

- In direct sunlight or in a dark room, the backlit liquid crystal display (LCD) can be read easily.
- Simultaneous display of instantaneous flow volume in %, actual flow volume in a variety of engineering units, and indication of total flow volume.
- When an integral model is installed on vertical or horizontal pipes, its display can be rotated through 90 degrees for better visibility.

Setting parameters by infrared touch sensor (optional)

- Parameters can be set without opening the cover of the converter.
- A special security feature has been incorporated to prevent inadvertent operation of the infrared touch sensor.

Field-replaceable electrodes

Electrodes are field-replaceable.

High performance lining

- High-quality PFA lining has excellent electrical and heat resistant characteristics, low surface friction, and high anti-adhesive properties.
- The PFA lining is particularly applicable for measurement of sticky pulps and gypsum slurries.

- PFA linings with diameter ranges from 2.5 to 600 mm (0.1 to 23.6 in.) available, making selection of the best lining easy for a wide variety of applications.
- The successful, embedded punch plate offers proven performance under conditions of rapid thermal change and/or negative pressure.

Rugged detector structure

- A stainless steel case is used for diameters of 2.5 to 200 mm (0.1 to 7.9 in.).

A wide variety of piping connections

- A hose, union joint, or clamp can be selected for very small diameter models [diameters of 2.5 to 15 mm (0.1 to 0.6 in.)].
- A flange structure is available for diameters of 25 to 600 mm (1 to 23.6 in.).
- A wafer construction can also be selected for diameters of 2.5 to 200 mm (0.1 to 7.9 in.).
- Diameters of 65, 125, and 450 mm (2.6, 5, and 17.7 in.) have been added to the existing product line.

Interchangeability

Can be used in combination with previous model detectors and converters.

Please consult your Honeywell representative for details.

Detector

Because the detector does the actual measuring of the flow rate, it serves as the primary element for MagneW 3000 **PLUS** flowmeters.

The detector measures the current generated by the conductive fluid as it moves through a magnetic field and sends this signal to the converter.

Available models are listed in Table 1.

Converter

The converter takes the electromotive-force signal from the detector and converts it to the instantaneous flow rate. That flow rate is output to the control equipment as either an analog or digital signal.

The converter also provides optional pulse outputs to drive counters and totalizers.

The converter has an optional Digital Operator Panel (DOP) which indicates the instantaneous flow rate or the integrated flow rate.

Because the converter is a current output-based device, the flowmeter can be configured and operated using the SFC. Or, the flowmeter can be configured and operated locally using the DOP.

The converter also supports the digital enhanced (DE) mode for direct digital communications with Honeywell's TPS system.

Available models are listed in Table 1.

Table 1—Available Models

DETECTORS			
Model	Lining	Pipe Connection	Diameter—mm (inches)
General/watertight	PFA	Union/hose/clamp	2.5 to 15 (0.1 to 0.6)
General/watertight	PFA Polyurethane rubber	Wafer	2.5 to 200 (0.1 to 7.9) 25 to 200 (1 to 7.9)
General/watertight	PFA Polyurethane rubber Chloroprene rubber	Flange	25 to 600 (1 to 23.6) 25 to 200 (1 to 7.9) 250 to 600 (10 to 23.6)
General/submersible	PFA	Union/hose/clamp	15 (0.6)
General/submersible	PFA Polyurethane rubber	Wafer	15 to 200 (0.6 to 7.9) 25 to 200 (1 to 7.9)
General/submersible	PFA Polyurethane rubber Chloroprene rubber	Flange	250 to 600 (10 to 23.6) 25 to 200 (1 to 7.9) 250 to 600 (10 to 23.6)
CONVERTERS			
General	Integral or remote type		

Operator Interface

The MagneW 3000 **PLUS** flowmeter can be configured, communicated with, and operated using

- a hand-held Smart Field Communicator (SFC),
- the flowmeter's optional Digital Operator Panel (DOP), and/or
- Honeywell's TPS system.

Communications can be quickly established with the MagneW 3000 **PLUS** through the SFC. It connects to the output terminals on the converter or anywhere along the 4 to 20 milliamper current line. Refer to Figure 3.

Operating parameters can be configured or operating data can be read by initiating simple keystroke sequences on the SFC. As shown in Figure 4, English language prompts in a two-line display guide the entry of configuration data such as:

- Pulse Parameters
- Detector Parameters
- Low Flow Cutoff
- Damping Time
- Range Parameters
- Input and Output Options
- Failsafe Mode

Pertinent operating data values are displayed in percent or user-selected engineering units for volume flow, mass flow, or time.

The optional DOP, allowing local configuration and operation of the flowmeter, contains

- a 7-segment, 6-digit main display, and
- a 16-digit, 2-line auxiliary display.

The main display indicates the instantaneous flow rate in percent of span, the instantaneous actual flow volume in selected engineering units, and the totalized flow volume (when pulse output is selected).

The auxiliary display allows the operator to monitor actions for entering/ changing configuration, operation, and calibration data, as well as checking diagnostic functions. These actions are performed using the DOP's four infrared touch sensor keys. Refer to Figure 5.

In the DE (Digital Enhanced) mode, the flowmeter can communicate digitally with Honeywell's TPS, and through a custom field termination assembly (FTA) to Allen-Bradley controllers.

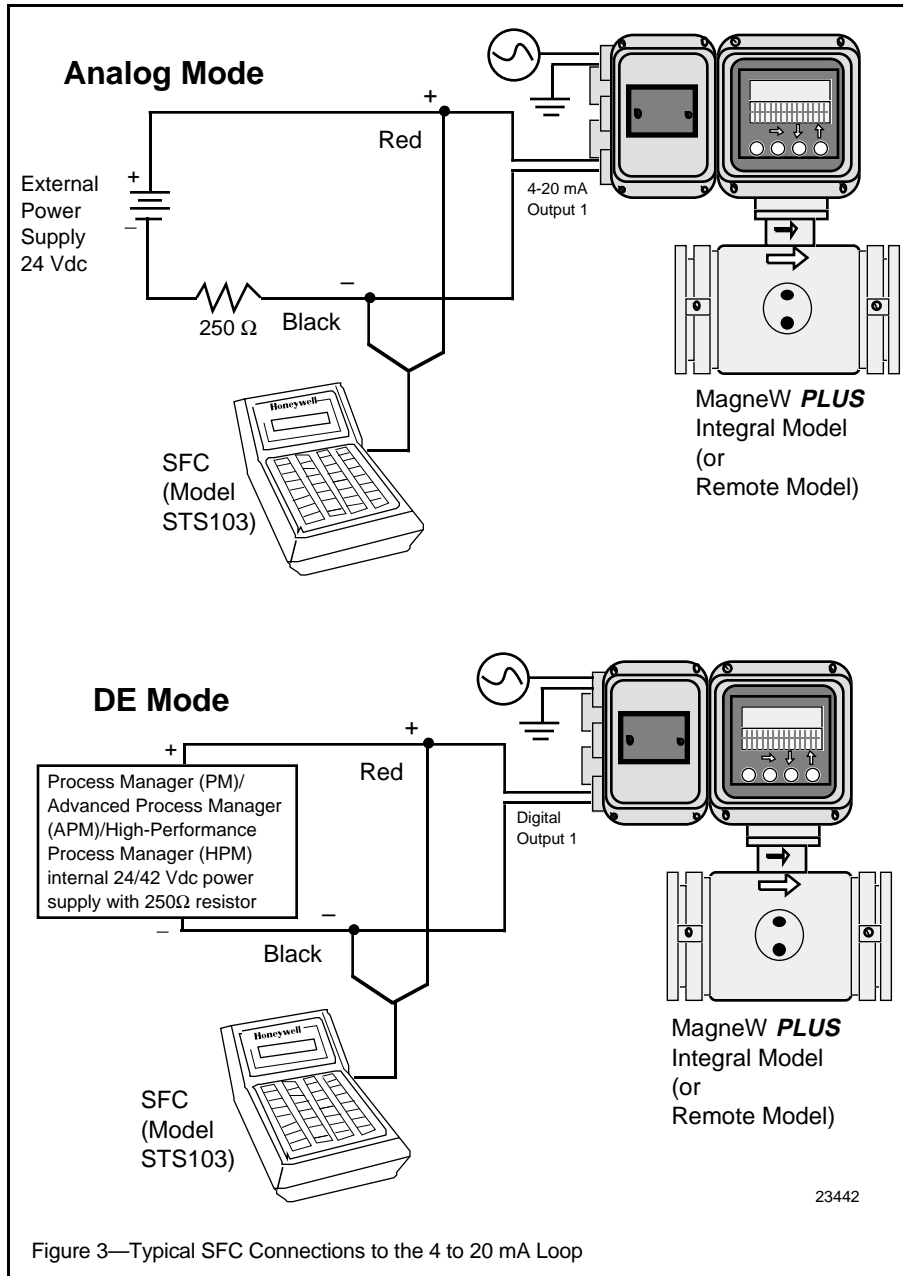

Figure 3—Typical SFC Connections to the 4 to 20 mA Loop

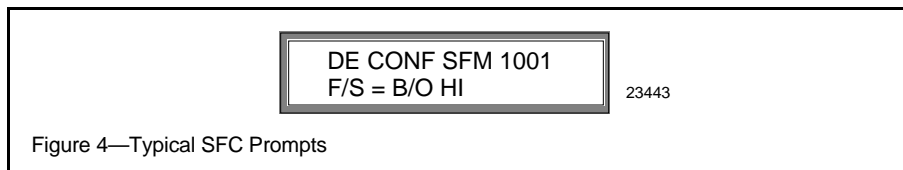

Figure 4—Typical SFC Prompts

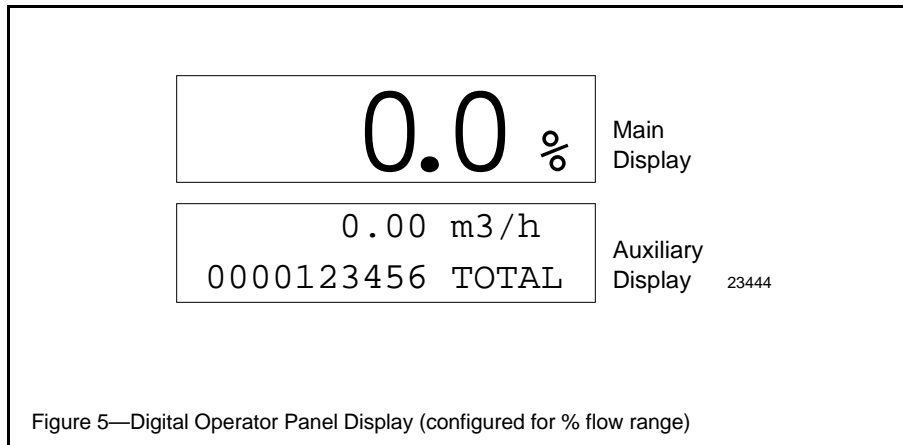

Figure 5—Digital Operator Panel Display (configured for % flow range)

Diagnostics

In the event of a malfunction, diagnostic messages speed up the troubleshooting process. Messages are available locally when using the optional DOP and via the SFC.

When operating in the DE mode, similar interface operations are possible through displays at the Universal Station^X (U^XS) or the Global User Station (GUS) in the TPS system.

Digital Communications Summary

The SFC (model STS103) can be used to “talk” to a flowmeter operating in either the analog or the DE (Digital Enhanced) mode. The SFC is connected across the current line at the flowmeter or any convenient point in the line. See Specification 34-ST-03-55 for more details about the SFC.

To “talk” to a flowmeter through displays at the Universal Station or GUS, the transmitter is connected to a Smart MV Transmitter Interface Input/Output Processor (STI IOP) in the Process Manager (PM), Advanced Process Manager (APM), or High-Performance Process Manager (HPM) through an FTA as shown in Figure 6. The flowmeter must be in the DE mode to communicate with the STI IOP.

Also, through a custom FTA the flowmeter, in the DE mode, can communicate with Allen-Bradley controllers.

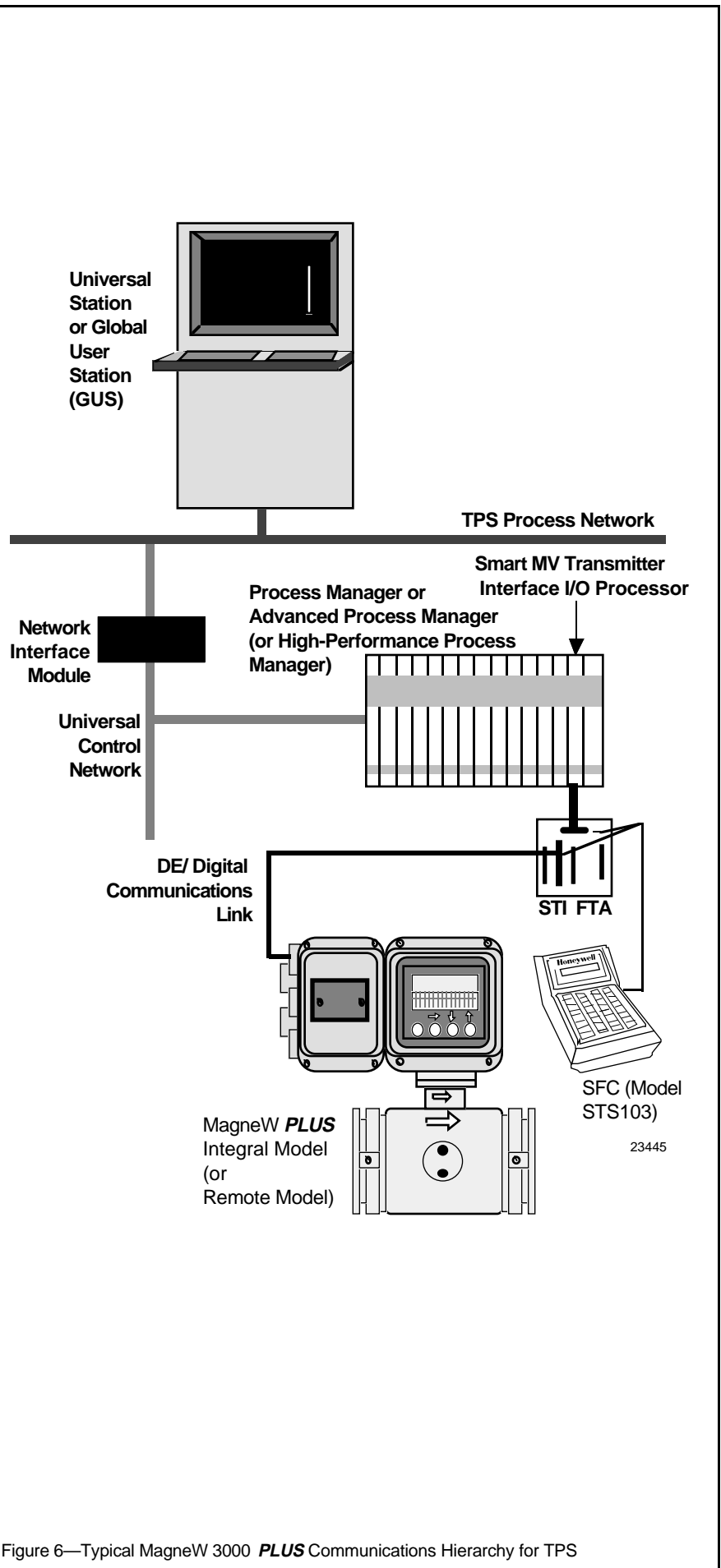

Figure 6—Typical MagneW 3000 **PLUS** Communications Hierarchy for TPS

Summary of MagneW 3000 PLUS Features

Table 2 provides a summary of major MagneW 3000 **PLUS** features and functions.

Table 2—Summary of Major MagneW 3000 PLUS Features

Feature	Function
Operating principle based on Faraday's Law	Provides accurate and reliable measurement of process fluid flow rate. The unit of flow indication can be in percentage, volume flow, mass flow, or time.
Flange-mounted detector	Provides a variety of process connections to match installation requirements.
4 to 20 milliampere signal or digital-enhanced output	Provides signal proportional to flow measurement in analog or digital form depending upon configuration.
SFC and TPS communications	Provide means to configure, operate, and troubleshoot MagneW through SFC and Universal Station or GUS in TPS system.
Optional built-in counter for pulse output models	<ul style="list-style-type: none"> • Totalizer: Depending on pulse direction setting, it totals one count at a time, for forward and reverse flows. • Totalizer with preset function: A preset value (target total) can be set between 000000 and 999999. Each forward and reverse flow signal is counted. • Forward/reverse flow difference totalizer: The difference in flow volumes in the forward and reverse directions is calculated and counted.
Optional 1- or 2-contact input	<ul style="list-style-type: none"> • External 0% lock input: Locks the flow rate signal (display, analog output, and pulse output) at 0%. • External zero adjustment input: Allows a zero point adjustment from a remote location. • External range switching input: Factory setting is <ul style="list-style-type: none"> – Range No. 1 or forward direction when opened – Range No. 2 or reverse direction when closed. • Built-in counter reset input (optional for pulse output model): Reset occurs when contact is ON for 0.2 seconds or more. Counting starts from counter reset value when contact turns OFF.
Optional 1- or 2-contact output	<ul style="list-style-type: none"> • Alarm contact output: An alarm is output when one of the following abnormal states occurs. <ul style="list-style-type: none"> – flow value alarm – self-diagnosis—coil disconnection, ROM error, RAM error, NVM error, ADC error, or – empty pipe detection. • Range switching output: Factory setting is <ul style="list-style-type: none"> – Range No. 1 or forward direction—when open – Range No. 2 or reverse direction—when closed • Counter preset status output (for pulse output model): Activates when the built-in counter reaches the preset value. • Self-diagnosis alarm output: Activates when the self-diagnosis function detects an abnormality. • Empty pipe detection alarm output (with empty-status detection): Activates when the fluid level in the detector goes below the electrode level. Alarm is available only when the electrical conductivity of the liquid is greater than 150μS/cm. • High/Low limit alarm: Activates when the flow volume exceeds the set upper and lower limit values. • Two-stage flow value alarm output (with two contact outputs): An alarm-actuating contact is output when the simultaneous flow value exceeds the set two upper limits (H and HH) or the two lower limits (L and LL).

Wiring Summary

External excitation and signal cables are required when connecting the remote detector/converter model.

Figure 7 provides an overview of possible wiring requirements for either model.

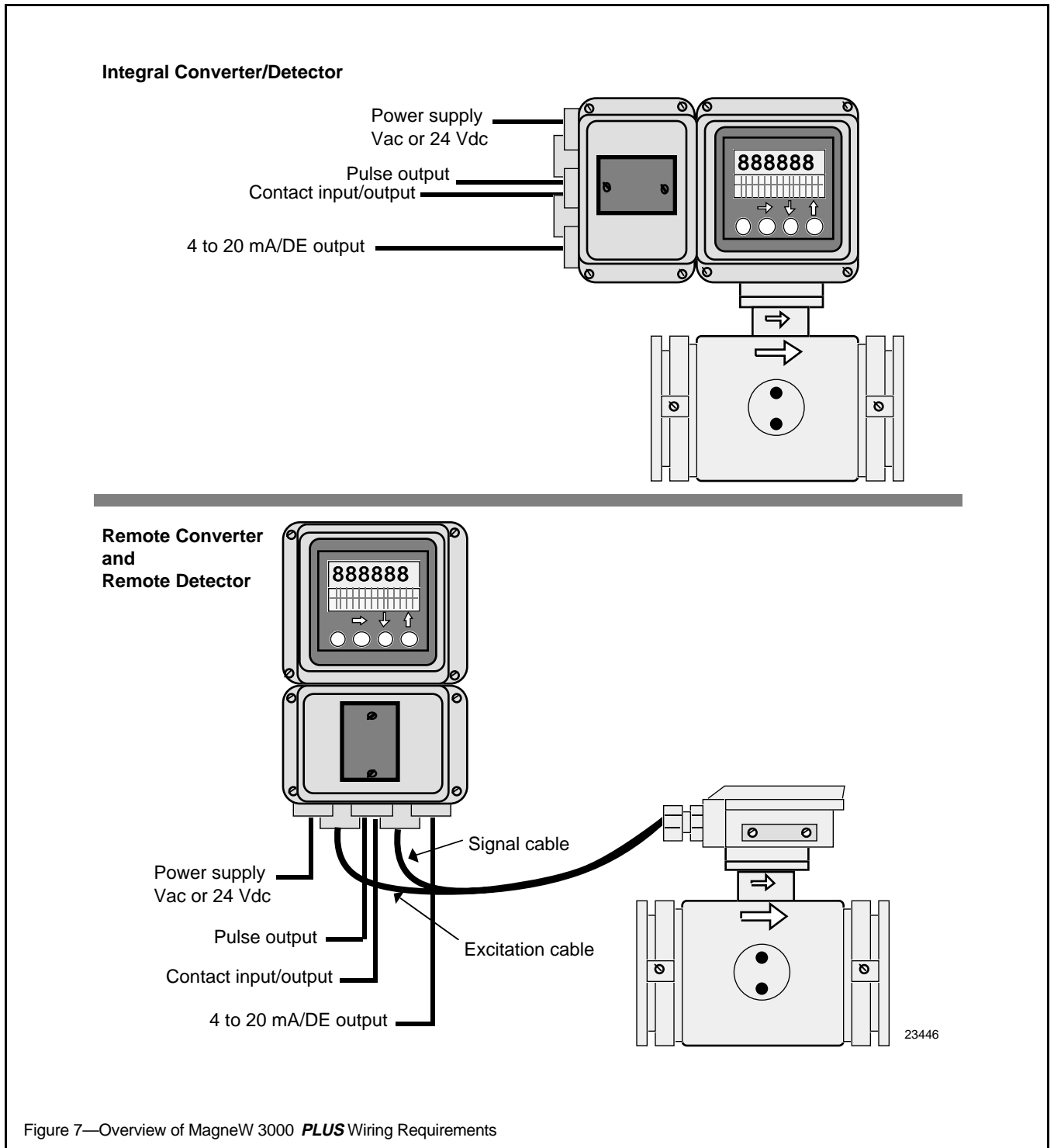

Figure 7—Overview of MagneW 3000 **PLUS** Wiring Requirements

Electrical Connection Considerations

For electrical connections of the converter/detector the following should be checked:

- Cable types
- Laying of cables
- Cable lengths
- Grounding

Cable Types

The standard cables for the instrument are as follows:

- *Signal cable*: 2-core individually double-shielded cable
- *Excitation cable*: 2-core chloroprene cabtyre cable

If standard cables are unavailable, contact Honeywell for recommendations.

Laying of Cables

- Do not lay the cables near a motor, a transformer, or a large-current cable which may cause induction noise. Lay the cables 1 meter (3.3 feet) or more away from heavy-duty power cables.
- Lay the signal cable in a metallic conduit, a flexible tube, or a duct, separately from the excitation current cable or any other power cables.
- Wire with electrical tube and duct to keep out water and protect the wire from external damage. Lay the tube so that no water gets into the unit.
- Use a waterproof gland at the conduit connection.
- Do not employ any junction point for connection of the signal cable or the exciting cable between the detector and the converter. When it is unavoidable to employ a junction point, use Cable Junction Box (Part No. 80720002-000) which has been designed specifically for this purpose.
- Do not short the excitation current terminals X and Y of the converter.

Cable Lengths

- The length of the cable between the detector and the converter depends on the electrical conductivity ($\mu\text{S/m}$) of the fluid to be measured. (Refer to Figure 9 on page 10.)

In general, the electrical conductivity of potable water or sewage water is of a level of $10000 \mu\text{S/m}$ ($100 \mu\Omega/\text{cm}$). Therefore, for a detector of 15 mm (0.6 in.) diameter or over, the maximum allowable cable length is 300 meters (984 feet).

- Signal Cable

If a signal cable is required to be laid more than 500 meters (1640 feet), select a cable cross section so that the voltage drop in the cable does not exceed 5V.

To calculate the excitation cable cross section area, use the following formula:

$$A \text{ (cross section area: mm}^2\text{)} = \frac{35.6 \times L \text{ (cable distance: m)} \times 0.4 \text{ (A)}}{1000 \times 5 \text{ (V)}}$$

- Current output cable (4-20 mA)
The allowable current output load of the converter is 0 to 600Ω . The sum of the cable resistance plus load resistance must be within this range. With a 2 mm^2 (0.003 in^2) cable, the cable resistance for both-ways between 1 km (3.281 ft.) distance is approximately 20Ω . When the receiver load is 400Ω , the current output cable can be extended up to 10 km (6.2 miles).
- Pulse output cable
Can be extended up to 1 km (3,281 ft.).

Grounding

- The grounding circuit should be less than 100Ω .
- At the converter side, ground the meter at the E terminal of the terminal block or the ground terminal of the case. The E terminal and the ground terminal are mutually connected in the unit.

Terminal Connections

Figure 8 shows typical wiring connections for both the integral and remote types.

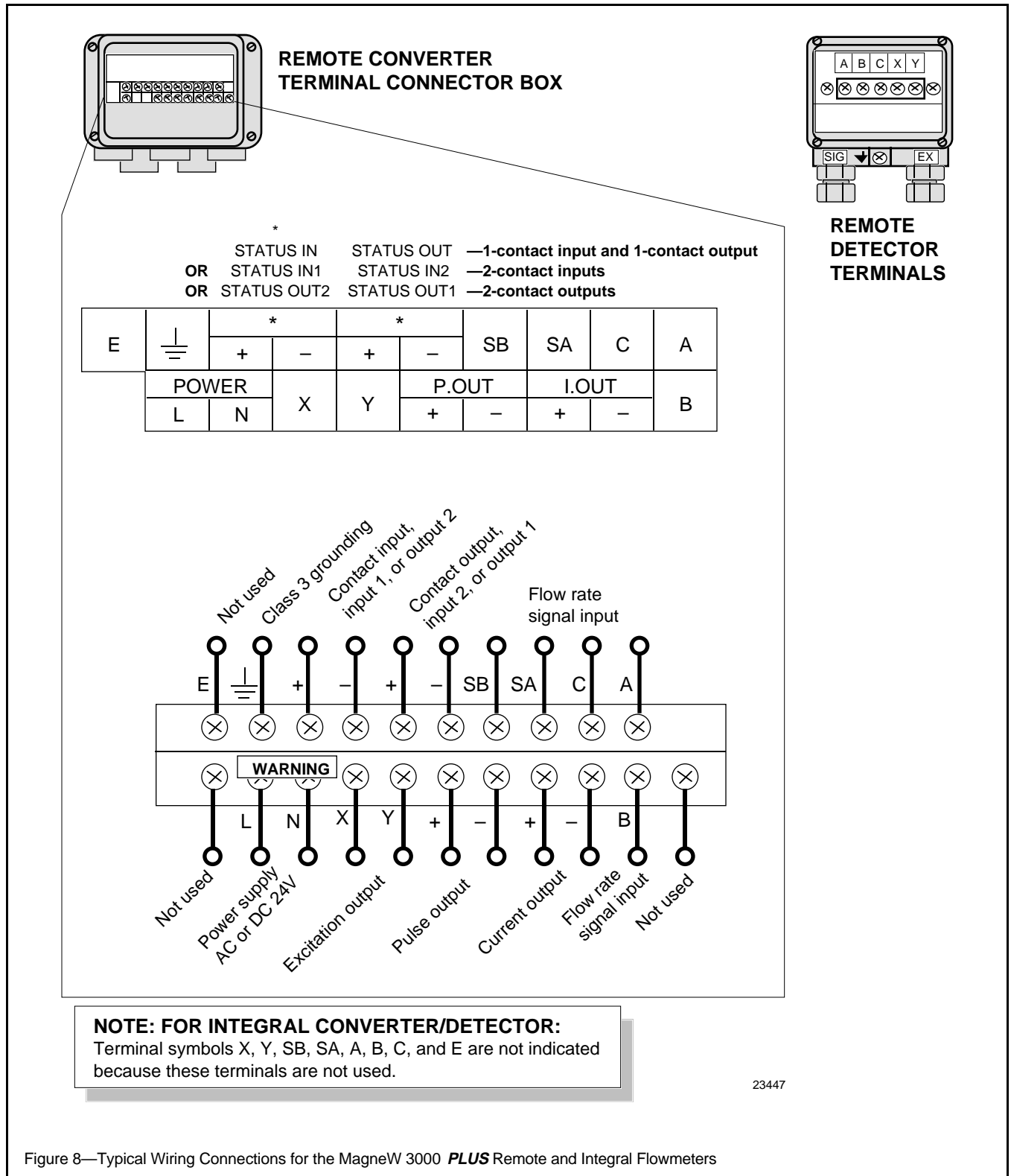

Cabling for Remote Detector/Converter

Honeywell offers the excitation and signal cables as a set under a separate model number (Model Number KIW-XXX-XXX). Commercially available cables can be used. The selection of the signal cables depends on certain conditions:

- fluid conductivity,
- length of cable, and
- diameter of the detector.

Figure 9 shows the relation between fluid conductivity and cable length.

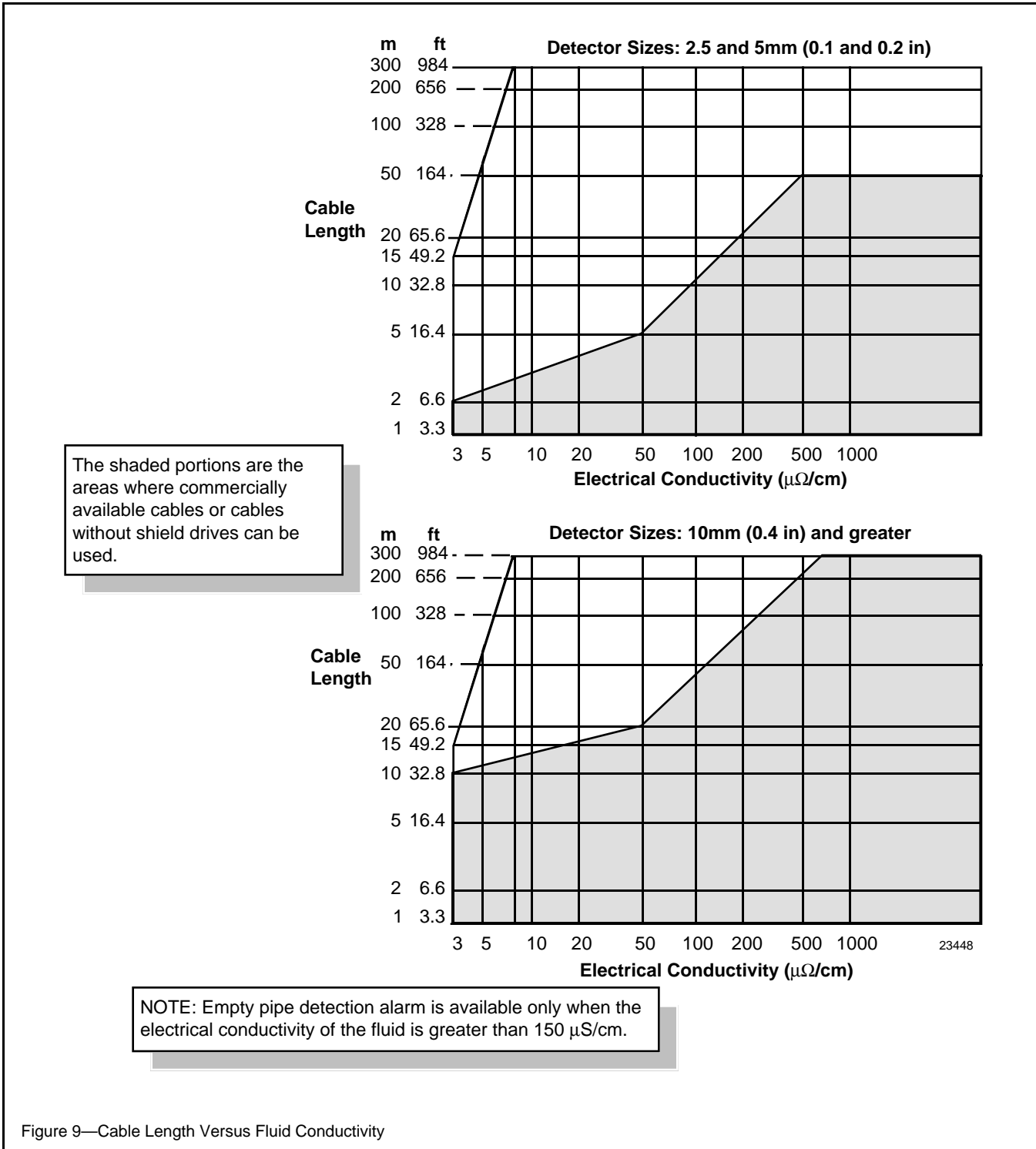

Figure 9—Cable Length Versus Fluid Conductivity

Ranging Function

The range function allows the operator to define the basic operating characteristics of the flowmeter. Table 3 explains the various function options that are available.

Table 3—Summary of Range Function Options

Type	Description	Analog Output	Pulse	Display	Contact	
					Input	Output
Single Range	<ul style="list-style-type: none"> Direct flow only with one 4 to 20 range 	Forward: 4-20 mA dc	Proportional	Positive	No effect	
		Reverse: -20% (0.8 mA)	Not delivered	Minus		
Direct, Dual Range, Auto Selection	<ul style="list-style-type: none"> Direct flow only with two ranges Switching between measuring ranges is automatic (Hysteresis is illustrated in Figure 10.) 	Both 4 to 20 mA dc	Pulse weight for both ranges is the same		No effect	Factory setting 1st range: open* 2nd range: closed*
Direct, Dual Range, External Selection	<ul style="list-style-type: none"> Direct flow only with two ranges Switching between ranges is done externally 	Both 4 to 20 mA dc	Pulse weight for both ranges is the same		Range select 1st range: open 2nd range: closed	Factory setting 1st range: open* 2nd range: closed* contact outputs (optional)
Direct/Reverse, Dual Range, Auto Selection	<ul style="list-style-type: none"> Direct and reverse flow with two ranges Switching between measuring ranges is automatic (Hysteresis illustrated in Figure 11) 	Both 4 to 20 mA dc	Pulse weight is same regardless of flow direction	Minus sign appears when flow is in reverse direction	No effect	Factory setting direct: open* reverse: closed*
Direct/Reverse, Dual Range, External Selection	<ul style="list-style-type: none"> Direct and reverse flow with two ranges Switching between ranges is done externally 	Both 4 to 20 mA dc	Pulse weight is same regardless of flow direction	Minus sign appears when flow is in reverse direction	Range select direct: open reverse: closed	Factory setting direct: open* reverse: closed* contact output (optional)

*Reverse setting is also possible.

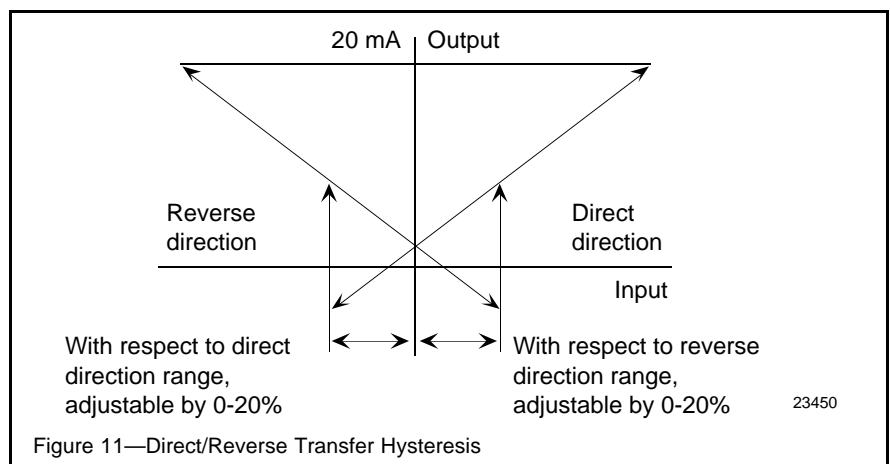
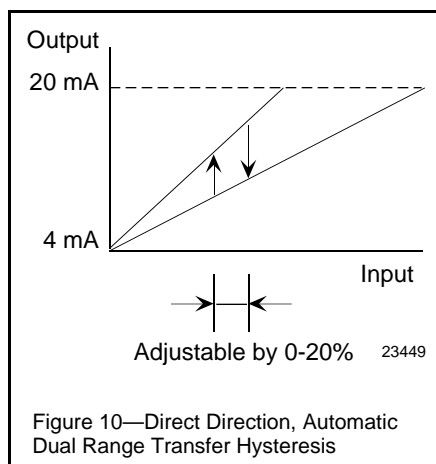

Selection of Corrosion-Resistant Materials

The corrosiveness of fluids used under practical conditions may vary according to the type and amount of impurities present, the operating temperatures, the variances in flow rate, and the concentration of fluids.

Selection of Lining Materials

The lining materials for use in the MagneW 3000 **PLUS** include Teflon PFA, alumina ceramic, polyurethane rubber, and chloroprene rubber. Their general characteristics are shown in Table 4.

Selection of Materials for Electrodes and Wet Contact Rings

The general characteristics of electrode materials is shown in Table 4.

Selection of Ground Ring Material

The same material for ground rings as for electrodes should be selected since both come in contact with fluids.

Table 4—Characteristics of Wet Contact Materials

Material	Main Component	Characteristics	Recommended Environment
Lining Materials			
Polyurethane rubber	Polyurethane	A synthetic elastic rubber. Excellent abrasion resistance. Little chemical resistance.	<i>Temperature:</i> –40 to +50°C (–40 to +122°F) <i>Pressure:</i> 426 psi maximum
Teflon PFA	Tetrafluoroethylene resin	A synthetic polymer containing fluorine (F) in the molecule. Resistant to almost all chemicals except for high-temperature fluorine, molten alkalis, and some halogen compounds. Excellent heat resistance together with a low friction characteristic and non-adhesiveness.	NOTE: Provides heat resistance in hot atmospheres. <i>Temperature:</i> –40 to +100°C (–40 to +212°F) for diameters 2.5 to 10 mm (0.1 to 0.4 in.) –40 to +160°C (–40 to +320°F) for diameters 15 to 200 mm (0.6 to 7.9 in.) –40 to +100°C (–40 to +212°F) for diameters 2.5 to 10 mm (0.1 to 0.4 in.) <i>Pressure:</i> Refer to Table 5, page 15.
Ceramic	Alumina ceramic Al ₂ O ₃ : 99.7%	Excellent friction resistance. Suited for high temperatures and high pressures. Chemical resistance is slightly lower than that of Teflon PFA. Weak to alkali fluids.	<i>Temperature:</i> –40 to +180°C (–40 to +356°F) <i>Pressure:</i> 1 to 40 kg/cm ² 14 psi maximum
Chloroprene rubber	Chloroprene	The friction and chemical resistances are almost comparable to those of polyurethane rubber.	<i>Temperature:</i> –10 to +70°C (14 to 158°F) <i>Pressure:</i> 142 psi maximum
Electrode Materials			
SUS316L	Cr : 17% Ni : 13% Mo : 2.25% C : <0.03% Fe : Remainder	Resistant to corrosion in a weak alkali or acidic atmosphere. Unusable in inorganic and organic acids, chlorides, etc.	Water (tap and sewage) and weak alkalis (such as caustic soda of 50% or less)
Titanium	Ti : >99.3%	Resistant to corrosion in an oxidizing atmosphere. In particular, usable in the presence of chlorine ions. Unusable in sulfuric acid, nitric acid, etc. (The empty-detection function of the converter cannot be used.)	A variety of chloride solutions (ammonium chloride, potassium chloride, ferrous chloride, etc.), sea water, etc.
Hastelloy C-276	Mo : 16% Cr : 16% Fe : 5% W : 4% Ni : Remainder	A wide range of uses since it is usable in moderately oxidizing and reducing atmospheres. Weak to sulfides, sulfuric acid, etc.	A variety of organic and inorganic acids, alkalis, etc.

Table 4—Characteristics of Wet Contact Materials, continued

Material	Main Component	Characteristics	Recommended Environment
<i>Electrode Materials (continued)</i>			
Tantalum	<p><i>For Teflon PFA lining:</i> Ta : >99.5%</p> <p><i>For ceramic use:</i> Ta : 90% W : 10%</p>	<p>Resistant to corrosion in strongly oxidizing and reducing atmospheres, but unusable in alkalis, fluorides, and fuming sulfuric acid.</p> <p>Because an insulating film may form on these electrodes, pay special attention to process conditions when selecting this material.</p> <p>(The empty-detection function of the converter cannot be used.)</p>	Concentrated hydrochloric acid, sulfuric acid, nitric acid, aqua regia, etc.
Platinum-iridium alloy	Pt : 90% Ir : 10%	Resistant to corrosion in almost all acids and alkalis except for aqua regia and ammonium salts. Very expensive.	Phosphoric acid, nitric acid, fluoric acid, hydrochloric acid, sulfuric acid, alkalis, etc.
Tungsten carbide		Highly abrasion-resistant and causes less slurry noise. Cannot be used for corrosive fluids.	Cement slurry, muddy slurry, filthy slurry, earth/sand slurry, etc.
Nickel		Highly corrosion-resistant against strong alkali fluids, especially against caustic soda and fluoric acid as compared with corrosion resistances of other metals.	Caustic soda, fluoric acid, alkali fluids, etc.
Zirconium		Corrosion-resistant against various chemicals, especially against sulfides.	Copper sulfide, formic acid, potassium hydroxide, etc.

Application Assistance

While the technical information provided in this guide is usually adequate for sizing a meter for a particular application, Honeywell has Application Assistance available. An Application Data Sheet (36-KI-08-01) is included at the end of this document. When completed it provides the information necessary for a thorough review by our Field Instrument Application Engineers. Using your application and installation information, process fluid data, and cost and operation objectives, these engineers will apply their wide industry experiences and various application software programs to assist in determining the most cost-effective flow solution available. To use this Honeywell service, please complete the Application Data Sheet and forward it to your Honeywell Representative for submission to Field Instrument Application Engineering.

Installation Planning Considerations

The MagneW 3000 **PLUS** planning considerations are summarized in Table 5. To ensure proper flowmeter selection and operation, the following installation conditions should be reviewed:

- Environmental conditions
- Fluid to be measured
- Measured liquid flow conditions
- Detector location in piping
- Clearance for maintenance and inspection

Table 5—Summary of Installation Considerations

Factor	Consideration
Environmental conditions	<p>The following should be considered when installing the MagneW 3000 PLUS.</p> <ul style="list-style-type: none"> • The ambient temperature should be within the following ranges: <ul style="list-style-type: none"> – <i>Integral model:</i> –25 to +60°C (–13 to +140°F) – <i>Remote converter:</i> –25 to +60°C (–13 to +140°F) – <i>Remote detector:</i> <ul style="list-style-type: none"> PFA lining: –30 to +80°C (–22 to +176°F) Polyurethane rubber or Chloroprene rubber lining: –30 to +60°C (–22 to +140°F) • Whenever possible, the flowmeter should not be exposed to direct sunlight, rain, or other unfavorable weather. • The flowmeter should be installed as far from any pump in the line as practical, so that the flow does not pulsate. • The flowmeter must not be subjected to severe vibration, as equipment damage could result. • The flowmeter must not be subjected to a highly corrosive atmosphere, as equipment damage could result. • The flowmeter must be installed sufficiently apart from high-current power lines, motors, transformers, or any other source of electromagnetic interference.

Table 5—Summary of Installation Considerations, continued

Factor	Consideration																																
Fluid to be measured	<p>The fluids to be measured must fall within MagneW 3000 PLUS specifications for:</p> <ul style="list-style-type: none"> • electrical conductivity—3μS/cm or greater • temperature • pressure <div data-bbox="519 367 1485 766"> </div> <p>LEGEND</p> <table border="1" data-bbox="519 808 1485 1176"> <thead> <tr> <th rowspan="2">Code</th> <th rowspan="2">Liner</th> <th rowspan="2">Detector Size mm (in.)</th> <th colspan="2">Temperature Range</th> </tr> <tr> <th>°C</th> <th>°F</th> </tr> </thead> <tbody> <tr> <td></td> <td>Polyurethane Rubber</td> <td>25 to 200 (1 to 7.9)</td> <td>-40 to 50</td> <td>-40 to 122</td> </tr> <tr> <td></td> <td>Teflon PFA</td> <td>2.5 to 10 (0.1 to 0.4)</td> <td>-40 to 100</td> <td>-40 to 212</td> </tr> <tr> <td></td> <td>Teflon PFA</td> <td>15 to 200 (0.6 to 7.9)</td> <td>-40 to 160</td> <td>-40 to 320</td> </tr> <tr> <td></td> <td>Teflon PFA</td> <td>250 to 600 (9.8 to 236)</td> <td>-40 to 120</td> <td>-40 to 248</td> </tr> <tr> <td></td> <td>Chloroprene Rubber</td> <td>250 to 600 (9.8 to 23.6)</td> <td>-10 to 70</td> <td>14 to 158</td> </tr> </tbody> </table>	Code	Liner	Detector Size mm (in.)	Temperature Range		°C	°F		Polyurethane Rubber	25 to 200 (1 to 7.9)	-40 to 50	-40 to 122		Teflon PFA	2.5 to 10 (0.1 to 0.4)	-40 to 100	-40 to 212		Teflon PFA	15 to 200 (0.6 to 7.9)	-40 to 160	-40 to 320		Teflon PFA	250 to 600 (9.8 to 236)	-40 to 120	-40 to 248		Chloroprene Rubber	250 to 600 (9.8 to 23.6)	-10 to 70	14 to 158
Code	Liner				Detector Size mm (in.)	Temperature Range																											
		°C	°F																														
	Polyurethane Rubber	25 to 200 (1 to 7.9)	-40 to 50	-40 to 122																													
	Teflon PFA	2.5 to 10 (0.1 to 0.4)	-40 to 100	-40 to 212																													
	Teflon PFA	15 to 200 (0.6 to 7.9)	-40 to 160	-40 to 320																													
	Teflon PFA	250 to 600 (9.8 to 236)	-40 to 120	-40 to 248																													
	Chloroprene Rubber	250 to 600 (9.8 to 23.6)	-10 to 70	14 to 158																													

Table 5—Summary of Installation Considerations, continued

Factor	Consideration
<p>Detector location in piping</p>	<p>The detector should be installed in the pipeline where it will always be filled with the measured fluid.</p>  <p>Air may be entrapped</p> <p>May not be filled with liquid</p> <p>Pump</p> <p>Good location</p> <p>Not filled with liquid</p> <p>Good location</p> <p>23452</p>
	<p>The face-to-face space between the flanges must be sufficient for the given detector size. Never force the detector into an insufficient face-to-face space.</p>  <p>23453</p>

Table 5—Summary of Installation Considerations, continued

Factor	Consideration						
<p>Detector location in piping (continued)</p>	<p>Straight pipe sections must be provided on the upstream and downstream sides of the detector as shown.</p> <div style="text-align: center; border: 1px solid black; padding: 10px;"> <p>UPSTREAM SIDE (D = Nominal diameter of detector)</p> <table border="1" style="width: 100%; border-collapse: collapse;"> <tr> <td style="width: 50%; padding: 5px;"> <p>90-degree elbow</p>  </td> <td style="width: 50%; padding: 5px;"> <p>Reducer pipe (can be regarded as a straight pipe section)</p>  </td> </tr> <tr> <td style="width: 50%; padding: 5px;"> <p>Sluice valve (full open)</p>  </td> <td style="width: 50%; padding: 5px;"> <p>Tee</p>  </td> </tr> <tr> <td style="width: 50%; padding: 5px;"> <p>Expansion pipe with cone angle 15 degrees or more (if the cone angle is less than 15 degrees, can be regarded as a straight pipe section)</p>  </td> <td style="width: 50%; padding: 5px;"> <p>Valve other than a sluice type</p>  </td> </tr> </table> <p style="text-align: center; margin-top: 10px;">DOWNSTREAM SIDE (D = Nominal diameter of detector)</p> <p style="text-align: center;">2D or greater (minimum 2D if drift current or the like is possible)</p> <p style="text-align: right; font-size: small;">23454</p> </div>	<p>90-degree elbow</p> 	<p>Reducer pipe (can be regarded as a straight pipe section)</p> 	<p>Sluice valve (full open)</p> 	<p>Tee</p> 	<p>Expansion pipe with cone angle 15 degrees or more (if the cone angle is less than 15 degrees, can be regarded as a straight pipe section)</p> 	<p>Valve other than a sluice type</p> 
<p>90-degree elbow</p> 	<p>Reducer pipe (can be regarded as a straight pipe section)</p> 						
<p>Sluice valve (full open)</p> 	<p>Tee</p> 						
<p>Expansion pipe with cone angle 15 degrees or more (if the cone angle is less than 15 degrees, can be regarded as a straight pipe section)</p> 	<p>Valve other than a sluice type</p> 						
	<p>The process piping with flanges must be straight and centered. Below are examples of improper alignments.</p> <div style="text-align: center; padding: 10px;">  <p style="display: flex; justify-content: space-around; margin-top: 5px;"> Tilted pipe Off-centered </p> <p style="text-align: right; font-size: small;">23455</p> </div>						

Table 5—Summary of Installation Considerations, continued

Factor	Consideration
<p>Clearance for maintenance</p>	<p>Sufficient space must be provided for maintenance of the electrodes and inspection of the terminals, and for operation of the converter with an integral type flowmeter.</p> <p>Suggested minimum clearances are provided below.</p>  <p style="text-align: right;">23456</p>

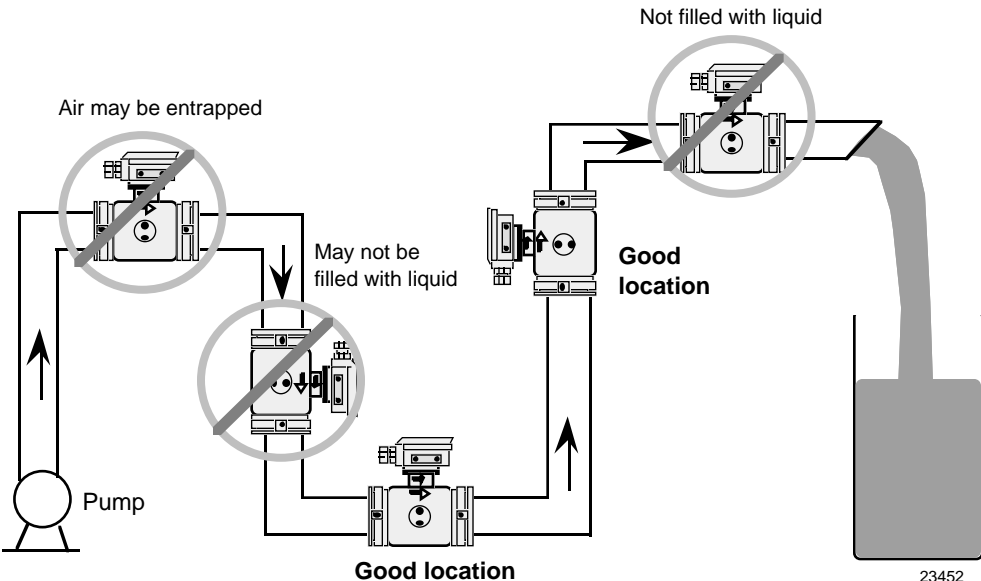
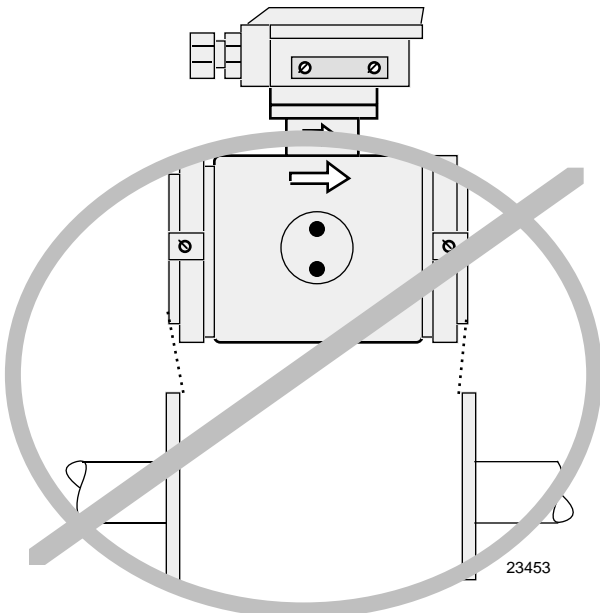
Specifications

Table 6 summarizes pertinent specification data for the MagneW 3000 **PLUS**.

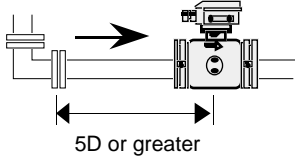
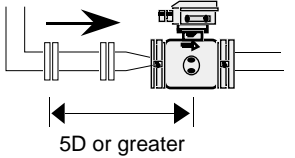
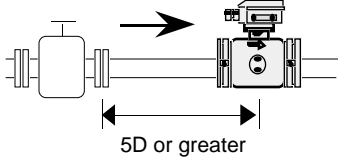
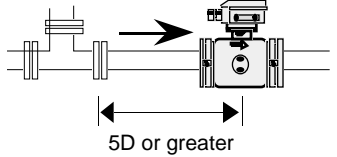
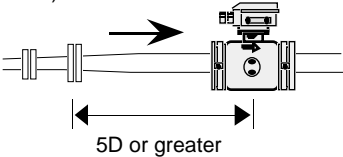
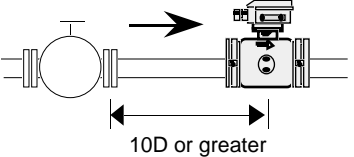
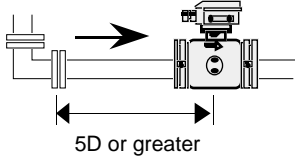
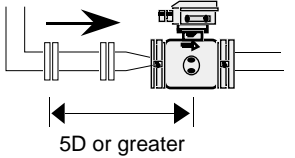
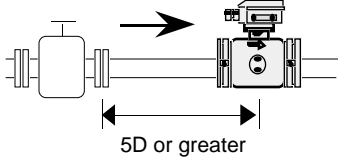
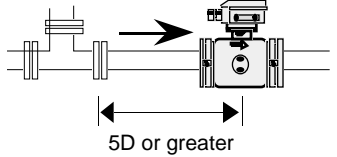
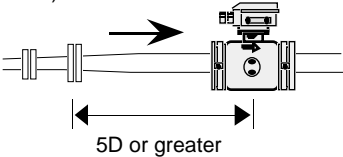
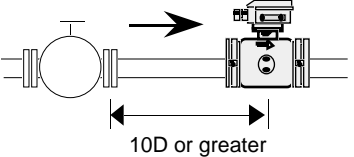
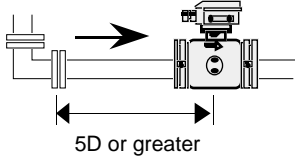
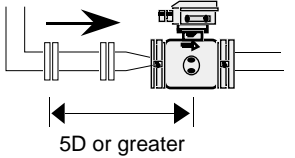
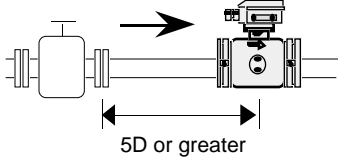
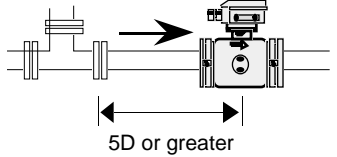
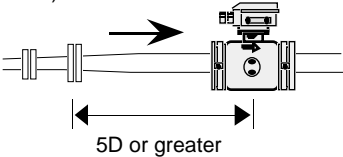
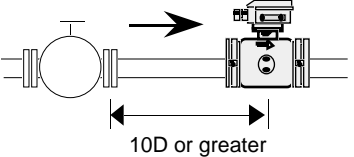
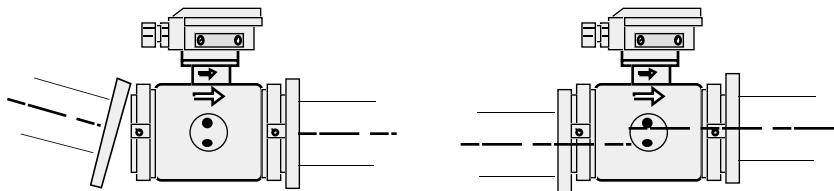
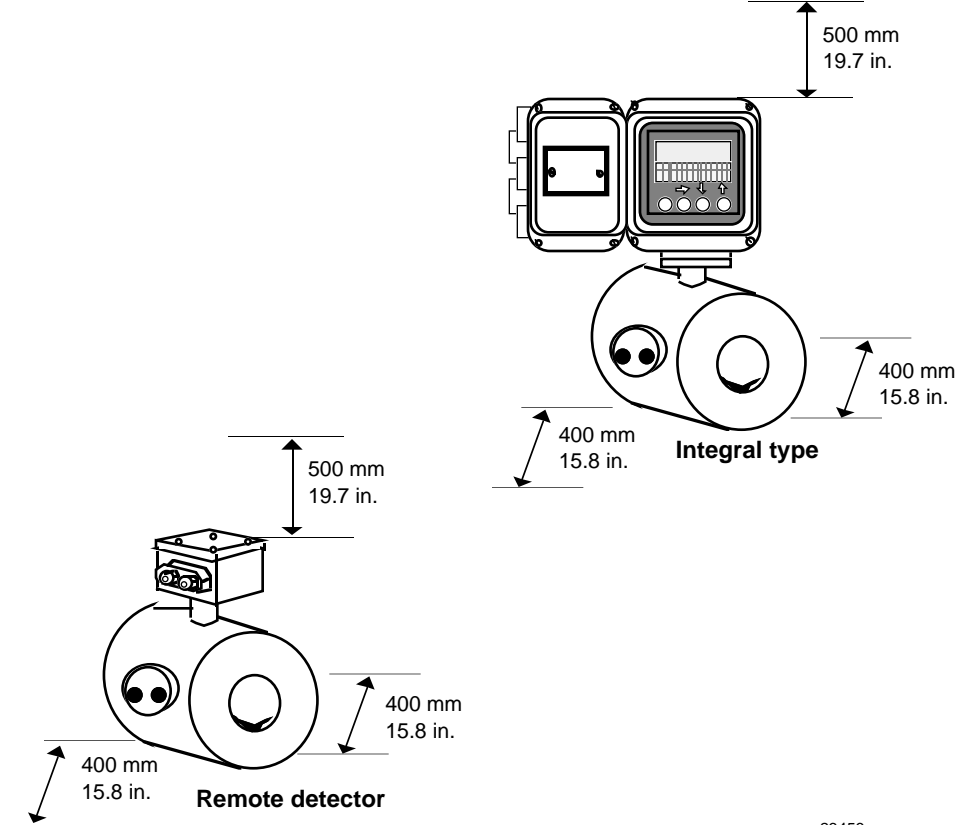
Table 6—Specifications for MagneW 3000 PLUS

Performance										
Accuracy	Refer to the following tables. <i>Diameters 2.5 mm to 15 mm (0.1 in. to 0.6 in.):</i> Upper limit value of Vs = set velocity range									
	<table border="1"> <thead> <tr> <th>Vs (m/s)</th> <th>Accuracy at Vs ≥40%</th> <th>Accuracy at Vs ≤ 40%</th> </tr> </thead> <tbody> <tr> <td>1.0 ≤ Vs ≤ 10</td> <td>±0.5% of indicated value</td> <td>±0.2% of Vs</td> </tr> <tr> <td>0.1 ≤ Vs ≤ 1.0</td> <td>±(0.1/Vs + 0.4%) of indicated value</td> <td>±0.4 (0.1/Vs + 0.4)% of Vs</td> </tr> </tbody> </table>	Vs (m/s)	Accuracy at Vs ≥40%	Accuracy at Vs ≤ 40%	1.0 ≤ Vs ≤ 10	±0.5% of indicated value	±0.2% of Vs	0.1 ≤ Vs ≤ 1.0	±(0.1/Vs + 0.4%) of indicated value	±0.4 (0.1/Vs + 0.4)% of Vs
	Vs (m/s)	Accuracy at Vs ≥40%	Accuracy at Vs ≤ 40%							
	1.0 ≤ Vs ≤ 10	±0.5% of indicated value	±0.2% of Vs							
	0.1 ≤ Vs ≤ 1.0	±(0.1/Vs + 0.4%) of indicated value	±0.4 (0.1/Vs + 0.4)% of Vs							
	<table border="1"> <thead> <tr> <th>Vs (m/s)</th> <th>Accuracy at Vs ≥20%</th> <th>Accuracy at Vs ≤20%</th> </tr> </thead> <tbody> <tr> <td>1.0 ≤ Vs ≤ 10</td> <td>±0.5% of indicated value</td> <td>±0.1% of Vs</td> </tr> <tr> <td>0.1 ≤ Vs ≤ 1.0</td> <td>±(0.1/Vs + 0.4%) of indicated value</td> <td>±0.2 (0.1/Vs + 0.4)% of Vs</td> </tr> </tbody> </table>	Vs (m/s)	Accuracy at Vs ≥20%	Accuracy at Vs ≤20%	1.0 ≤ Vs ≤ 10	±0.5% of indicated value	±0.1% of Vs	0.1 ≤ Vs ≤ 1.0	±(0.1/Vs + 0.4%) of indicated value	±0.2 (0.1/Vs + 0.4)% of Vs
Vs (m/s)	Accuracy at Vs ≥20%	Accuracy at Vs ≤20%								
1.0 ≤ Vs ≤ 10	±0.5% of indicated value	±0.1% of Vs								
0.1 ≤ Vs ≤ 1.0	±(0.1/Vs + 0.4%) of indicated value	±0.2 (0.1/Vs + 0.4)% of Vs								
<i>Diameters 25 mm to 600 mm (1 in. to 23.6 in.):</i> Upper limit value of Vs = set velocity range										
<table border="1"> <thead> <tr> <th>Vs (m/s)</th> <th>Accuracy at Vs ≥20%</th> <th>Accuracy at Vs ≤20%</th> </tr> </thead> <tbody> <tr> <td>1.0 ≤ Vs ≤ 10</td> <td>±0.5% of indicated value</td> <td>±0.1% of Vs</td> </tr> <tr> <td>0.1 ≤ Vs ≤ 1.0</td> <td>±(0.1/Vs + 0.4%) of indicated value</td> <td>±0.2 (0.1/Vs + 0.4)% of Vs</td> </tr> </tbody> </table>		Vs (m/s)	Accuracy at Vs ≥20%	Accuracy at Vs ≤20%	1.0 ≤ Vs ≤ 10	±0.5% of indicated value	±0.1% of Vs	0.1 ≤ Vs ≤ 1.0	±(0.1/Vs + 0.4%) of indicated value	±0.2 (0.1/Vs + 0.4)% of Vs
Vs (m/s)	Accuracy at Vs ≥20%	Accuracy at Vs ≤20%								
1.0 ≤ Vs ≤ 10	±0.5% of indicated value	±0.1% of Vs								
0.1 ≤ Vs ≤ 1.0	±(0.1/Vs + 0.4%) of indicated value	±0.2 (0.1/Vs + 0.4)% of Vs								
Design										
Flow Velocity Ranges	0-0.1 m/s to 0-10 m/s (0-0.3 ft/s to 0-30 ft/s) The range can be set locally through the DOP or remotely through the SFC. See Table 7 for minimum and maximum ranges by diameter.									
Electrical Conductivity of Liquid	300 microsiemens/m (3 micromhos/cm) minimum.									
Liquid Pressure and Temperature Ranges for Detector	See Table 5, Page 14.									
Damping Time Constant	Variable from 0.5 to 199.9 seconds.									
Low Flow Cutoff	Current output corresponding to 0-10% of set range (variable integer)									
Dropout	Pulse output corresponding to 0-10% of set range (variable integer) for 20 kHz maximum									
Lightning Protection	12 kV, 1000A Incorporated into the power source and external input and output terminals.									
Power Failure	EEPROM retains data record of total flow volume when pulse output is used (retention period approximately 10 years).									
Input (Transmitter)	Detector flow signals plus external selections that drive a semiconductor or no-voltage open-close contact signal for any one of the following functions: <ul style="list-style-type: none"> • <i>External 0% lock:</i> Enables 0% stop of the flow indication, analog output, digital output, and pulse output via contact input. • <i>External automatic zero adjustment:</i> Adjusts the zero point by contact input. • <i>External range changeover:</i> Switches dual range or forward/reverse range by contact input. • <i>Built-in counter reset (optional for pulse output model):</i> Resets the total flow volume value of the built-in counter by contact input. 									

Table 6—Specifications for MagneW 3000 PLUS, continued

Design (continued)	
Outputs (Transmitter)	<ul style="list-style-type: none"> • Detector's coil excitation current • <i>Current output without SFC communications requirement:</i> 4 to 20 mA dc into a 0 to 600 ohms load with external 24 Vdc power supply. • <i>Current output with SFC/DE communications requirement:</i> 4 to 20 mA dc into a 250 to 1460 ohms load with an external 24 Vdc power supply. <div style="text-align: center;"> $\text{Load Resistance } (\Omega) = \frac{\text{Supply voltage } 8.5}{0.025}$ <p style="text-align: right; margin-right: 50px;">21703</p> </div> <ul style="list-style-type: none"> • <i>Contact output:</i> For a maximum external load of 30 Vdc/200 mA, indicating any one of the following condition states: <ul style="list-style-type: none"> – Alarm actuating contacts for <ul style="list-style-type: none"> <u>Self-diagnosis alarm</u>—Outputs an alarm-actuating contact when the self-diagnosis function detects an error. <u>No-load detection alarm (with empty-status detection)</u>—Outputs an alarm-actuating contact when the fluid level in the detector goes below the electrode level. <u>Upper/lower flow limit value alarm</u>—Outputs an alarm-actuating contact when the flow volume exceeds the upper/lower limit values. <u>Two-stage flow value alarm (with two contact outputs)</u>—Outputs an alarm-actuating contact when the flow value exceeds the two upper limits (H and HH) or the two lower limits (L and LL). – Range identification output—Outputs a contact for large and small ranges, forward and reverse direction ranges. – Counter preset status (for pulse output model)—Outputs a contact when the built-in counter reaches the preset value.
Display	<p>Display card can rotate 90° for installation on vertical pipe. Backlit liquid crystal display (LCD). <i>Display board:</i> One line with six 7-segmented digits—Main display Dot matrix, two lines with 16 columns—Auxiliary display</p> <p><i>Display contents:</i></p> <ul style="list-style-type: none"> • instantaneous flow rate in percent • instantaneous actual flow rate in a variety of engineering units • total volume (with pulse output model) • engineering data
Operator Interface	<p>Four infrared touch sensor keys OR Hand-held communicator with keyboard and LCD. Connects anywhere in the 4-20 mA output line.</p>
Mounting	<p><i>Converter:</i></p> <ul style="list-style-type: none"> • Integral mounts directly on detector • Remote mounts on wall or 2-inch pipe <p><i>Detector:</i> A variety of piping connections are offered—flange, wafer, hose, sanitary coupling, etc.</p>

Table 6—Specifications for MagneW 3000 PLUS, continued

<i>Design (continued)</i>	
Flange Rating	<ul style="list-style-type: none"> • 25 to 50 mm (1 to 2 in.) diameters: JIS 10K, JIS 16K, JIS 20K, JIS 30K, JPI 150, JPI 300, ANSI 150, ANSI 300, DIN PN10, DIN PN16, DIN PN25, DIN PN40 • 80 to 200 mm (3.2 to 7.9 in.) diameters: JIS 10K, JIS 20K, JIS 30K, JPI 150, JPI3 00, ANSI 150, ANSI 300, DIN PN10, DIN PN16, DIN PN25, DIN PN40, JIS G3451 F12 • 250 to 600 mm (9.8 to 23.6 in.) diameters with PFA lining: JIS 10K, JIS 16K, JIS 20K, JPI 150, JPI3 00, ANSI 150, ANSI 300, DIN PN10, DIN PN16, DIN PN25, JIS G3451 F12 • 250 to 600 mm (9.8 to 23.6 in.) diameters with chloroprene rubber lining: JIS 10K, JPI 150, ANSI 150, DIN PN10, JIS G3451 F12
Structure	<p><i>Converter:</i> NEMA 4X, IEC IP66, JIS C 0920 waterproof model</p> <ul style="list-style-type: none"> • Converter can rotate 180°. <p><i>Detector:</i></p> <ul style="list-style-type: none"> • NEMA 4X, IEC IP67, JIS C 0920 watertight model • NEMA 6, IEC IP68, JIS C 0920 submersible model <p><i>Electrode</i></p> <ul style="list-style-type: none"> • Watertight—External insertion (electrode can be removed) • Submersible—Internal insertion (electrode cannot be removed)
Finish	<p><i>Converter:</i> acrylic resin</p> <p><i>Detector:</i></p> <ul style="list-style-type: none"> • <u>Watertight:</u> 2.5 to 200 mm (0.1 to 7.9 in.) diameters, terminal box only of remote model—corrosion-preventive acrylic resin 250 to 600 mm (9.8 to 23.6 in.) diameters, terminal box of remote model and case of remote/integral models—Corrosion-preventive polyurethane resin • <u>Submersible:</u> 15 to 200 mm (0.6 to 7.9 in) diameters, terminal box only; and 250 to 600 mm (9.8 to 23.6 in.) diameters, terminal box and case—Corrosion-preventive tar epoxy
Color	<p><i>Converter:</i> light beige</p> <p><i>Detector:</i></p> <ul style="list-style-type: none"> • Watertight: light beige • Submersible: black
Material	<p><i>Converter:</i></p> <ul style="list-style-type: none"> • Main body—Aluminum alloy • Display cover—Tempered glass, 5 mm thick; aluminum alloy <p><i>Detector:</i></p> <ul style="list-style-type: none"> • Flange 25 to 65 mm (1 to 2.6 in.) diameters—SUS304 stainless steel 80 to 600 mm (3.2 to 23.6 in.) diameters—carbon steel plus corrosion-preventive coating • Case 2.5 to 15 mm (0.1 to 0.6 in) diameters—SCS13 stainless steel 25 to 200 mm (1 to 7.9 in.) diameters—SUS304 stainless steel 250 to 600 mm (9.8 to 23.6 in.) diameters—SS400 carbon steel • Terminal box—Aluminum alloy (remote model)

Table 6—Specifications for MagneW 3000 PLUS, continued

<i>Design (continued)</i>	
Wetted Materials	<p><i>Lining:</i></p> <ul style="list-style-type: none"> • 2.5 to 600 mm (0.1 to 23.6 in.) diameters—PFA • 25 to 200 mm (1 to 7.9 in.) diameters—polyurethane rubber • 250 to 600 mm (9.8 to 23.6 in.) diameters—chloroprene rubber <p><i>Electrode:</i> SUS316L, Hastelloy C, Titanium, Zirconium, Tantalum, Tungsten-Carbide, Platinum/Iridium</p> <p><i>Ground ring:</i> SUS316, Hastelloy C, Titanium, Zirconium, Tantalum, Platinum</p> <p><i>Union joint for diameters 2.5 to 15 mm (0.1 to 0.6 in.):</i> SUS316</p> <p><i>Hose for diameters 2.5 to 15 mm (0.1 to 0.6 in.):</i> SUS316</p> <p><i>IDF clamp:</i> SUS316</p> <p><i>Tri-clamp:</i> SUS316</p> <p><i>Gasket:</i> PTFE gaskets are supplied with ground rings of Hastelloy C, Titanium, Zirconium, Tantalum, and Platinum. For ground rings made of SUS316, gaskets are supplied by customer; non-rubber, such as PTFE or joint sheet, is recommended.</p> <p><i>O-ring:</i> Viton rubber (with union joints)</p>
Electrical Conduit	1/2 inch NPT, G1/2, CM20, Pg13.5 internal threads, optional plastic and brass waterproof glands (G1/2 only)
Nuts and Bolts	For wafer construction models only S20C carbon steel, SUS304 stainless steel
Electrical Connection	<p><i>Integral:</i> M4-12P screw terminals</p> <p><i>Remote:</i></p> <ul style="list-style-type: none"> • Converter—M4-19P screw terminals • Detector—M4-5P screw terminals
Cables	<p><i>Signal cable:</i> 2-core individually double-shielded cable</p> <p><i>Coil excitation current cable:</i> 2-core chloroprene cabtyre cable</p>
Cable Length	300 meters (984 feet) maximum
Grounding	Category 3 100 ohms maximum ground resistance
Dimensions	See Figures 12 through 20, as applicable.
Weight	<p><i>Converter:</i> 3.7 kg (8.2 lbs)</p> <p><i>Detector:</i> Refer to Table 8, 9, or 10, as applicable.</p>

Table 6—Specifications for MagneW 3000 PLUS, continued

Environmental and Operating Conditions			
Ambient Temperature	<p><i>Converter:</i> -25 to +60°C (-13 to +140°F)</p> <p><i>Detector:</i></p> <ul style="list-style-type: none"> • Integral model: -25 to +60°C (-13 to +140°F) • Remote model, PFA lining: -30 to +80°C (-22 to +176°F) • Remote model, polyurethane rubber lining/chloroprene rubber lining: -30 to +60°C (-22 to +140°F) 		
Relative Humidity	5 to 100%		
Power Requirements	<ul style="list-style-type: none"> • <i>Voltage (Vac) ±10%:</i> 100, 110, 115/120, 200, 220, 230/240 • <i>Voltage (Vdc) ±10%:</i> 24 • <i>Frequency:</i> 50 or 60 Hz 		
Power Consumption	13W (17 VA)		
Approval Bodies	<u>Model No.</u>	<u>Approval Body</u>	<u>Approval Type and Classification</u>
	MGG14C Remote Converter	CSA and FM	Nonincendive – Class I, II, III, Division 2, Groups A, B, C, D, E, G
	MGG17D, F, U Remote Detector	CSA and FM	Special Protection – Class I, II, III, Division 1, Groups B, C, D, E, F, G
	MGG18D, F, U Remote Detector (Water Tight)	CSA and FM	Nonincendive – Class I, II, II, Division 2, Groups A, B, C, D, F, G
	MGG19D, F, U Remote Detector (Submersible)	CSA and FM	Nonincendive – Class I, II, III, Division 2, Groups A, B, C, D, F, G
	MGG14C (Converter) MGG18D, F, U Integral Unit	CSA and FM	Nonincendive – Class I, II, III, Division 2, Groups A, B, C, D, F, G
	MGG16D, F, U Remote Detector	CENELEC	EEx de ia II CT4
CE Mark Conformity (Europe)	MagneW 3000 PLUS meets the emission limits for EN 50081-1-1993 and the immunity standards for EN 50082-2-1995.		

Table 7—Minimum and Maximum Ranges

Diameter mm (inches)	Minimum Range—m³/h (ft³/h) [Minimum constant flow speed of 0 to 0.1 m/s (0 to 0.3 ft/s)]	Maximum Range—m³/h (ft³/h) [Maximum constant flow speed of 0 to 10 m/s (0 to 30 ft/s)]
2.5 (0.1)	0 to 0.00177 (0 to 0.625)	0 to 0.177 (0 to 6.25)
5 (0.2)	0 to 0.00707 (0 to 0.2498)	0 to 0.707 (0 to 24.98)
10 (0.4)	0 to 0.0283 (0 to 1)	0 to 2.83 (0 to 100)
15 (0.6)	0 to 0.0636 (0 to 2.24)	0 to 6.36 (0 to 224.73)
25 (1)	0 to 0.177 (0 to 6.25)	0 to 17.7 (0 to 625.44)
40 (1.6)	0 to 0.452 (0 to 15.97)	0 to 45.2 (0 to 1,597.17)
50 (2.0)	0 to 0.707 (0 to 24.98)	0 to 70.7 (0 to 2,498.23)
65 (2.6)	0 to 1.19 (0 to 42.04)	0 to 119 (0 to 4,204.94)
80 (3.1)	0 to 1.81 (0 to 63.95)	0 to 181 (0 to 6,395.75)
100 (3.9)	0 to 2.83 (0 to 100)	0 to 283 (0 to 10,000)
125 (4.9)	0 to 4.42 (0 to 156.18)	0 to 442 (0 to 15,618.37)
150 (5.9)	0 to 6.36 (0 to 224.73)	0 to 636 (0 to 22,473.49)
200 (7.9)	0 to 11.31 (0 to 399.64)	0 to 1,131 (0 to 39,964.66)
250 (9.8)	0 to 17.67 (0 to 624.38)	0 to 1,767 (0 to 62,438.16)
300 (11.8)	0 to 25.45 (0 to 899.29)	0 to 2,545 (0 to 89,929.32)
350 (13.8)	0 to 34.64 (0 to 1,224.02)	0 to 3,464 (0 to 122,402.82)
400 (15.8)	0 to 45.24 (0 to 1,598.58)	0 to 4,524 (0 to 159,858.65)
450 (17.7)	0 to 57.26 (0 to 2,023.32)	0 to 5,726 (0 to 202,332.15)
500 (19.7)	0 to 70.70 (0 to 2,498.23)	0 to 7,070 (0 to 249,823.32)
600 (23.6)	0 to 101.79 (0 to 3,596.81)	0 to 10,179 (0 to 359,681.97)

Dimensions

Figures 12 through 20 and Tables 8 through 10 list reference dimensions for the various MagneW 3000 **PLUS** styles and sizes.

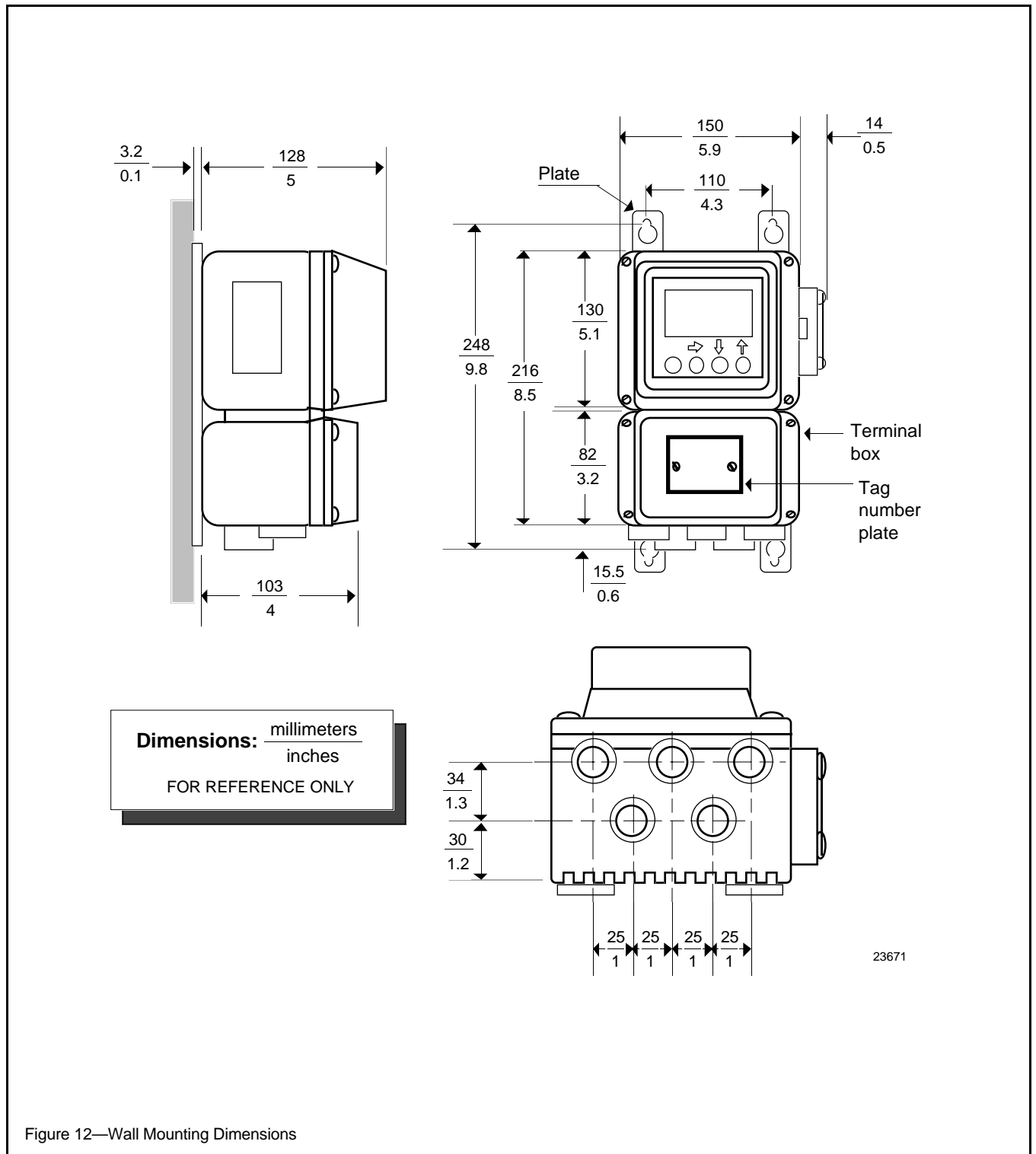
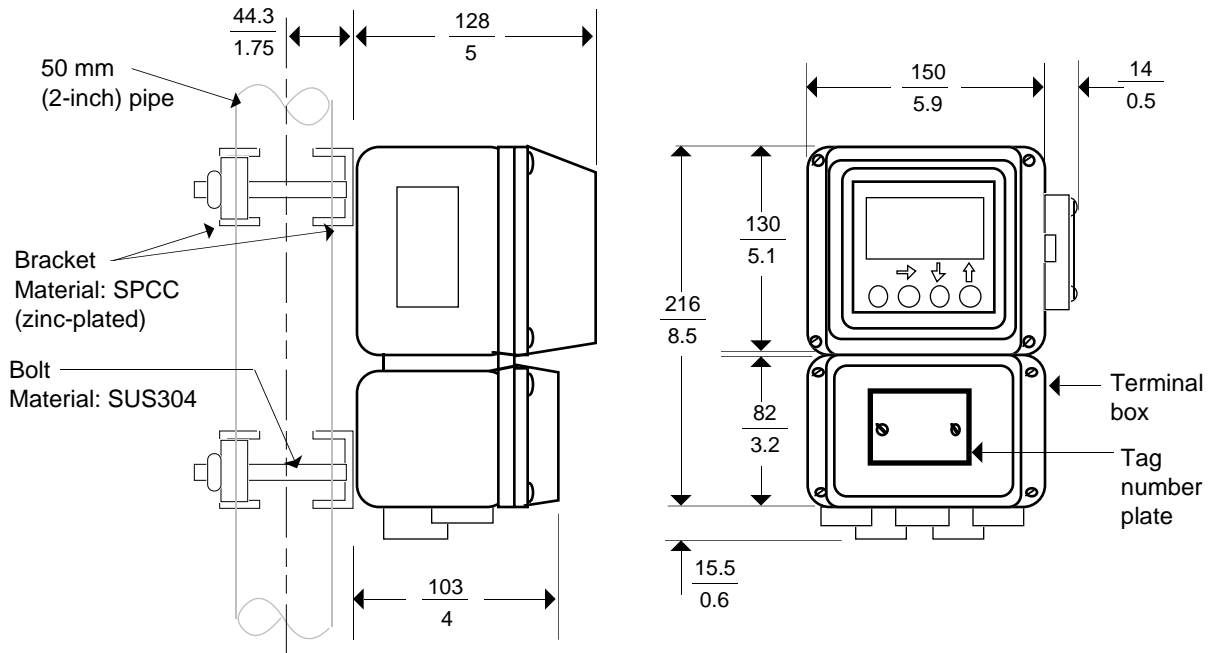
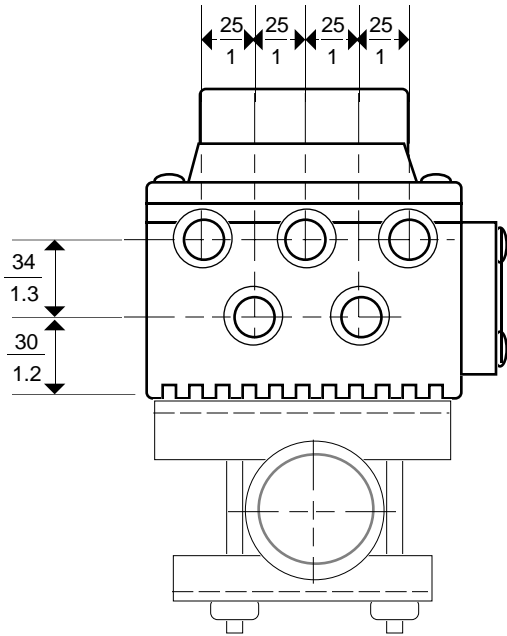

Figure 12—Wall Mounting Dimensions



Dimensions: $\frac{\text{millimeters}}{\text{inches}}$
FOR REFERENCE ONLY



23672

Figure 13—2-inch Pipe Mounting Dimensions

Dimensions: $\frac{\text{millimeters}}{\text{inches}}$
 FOR REFERENCE ONLY

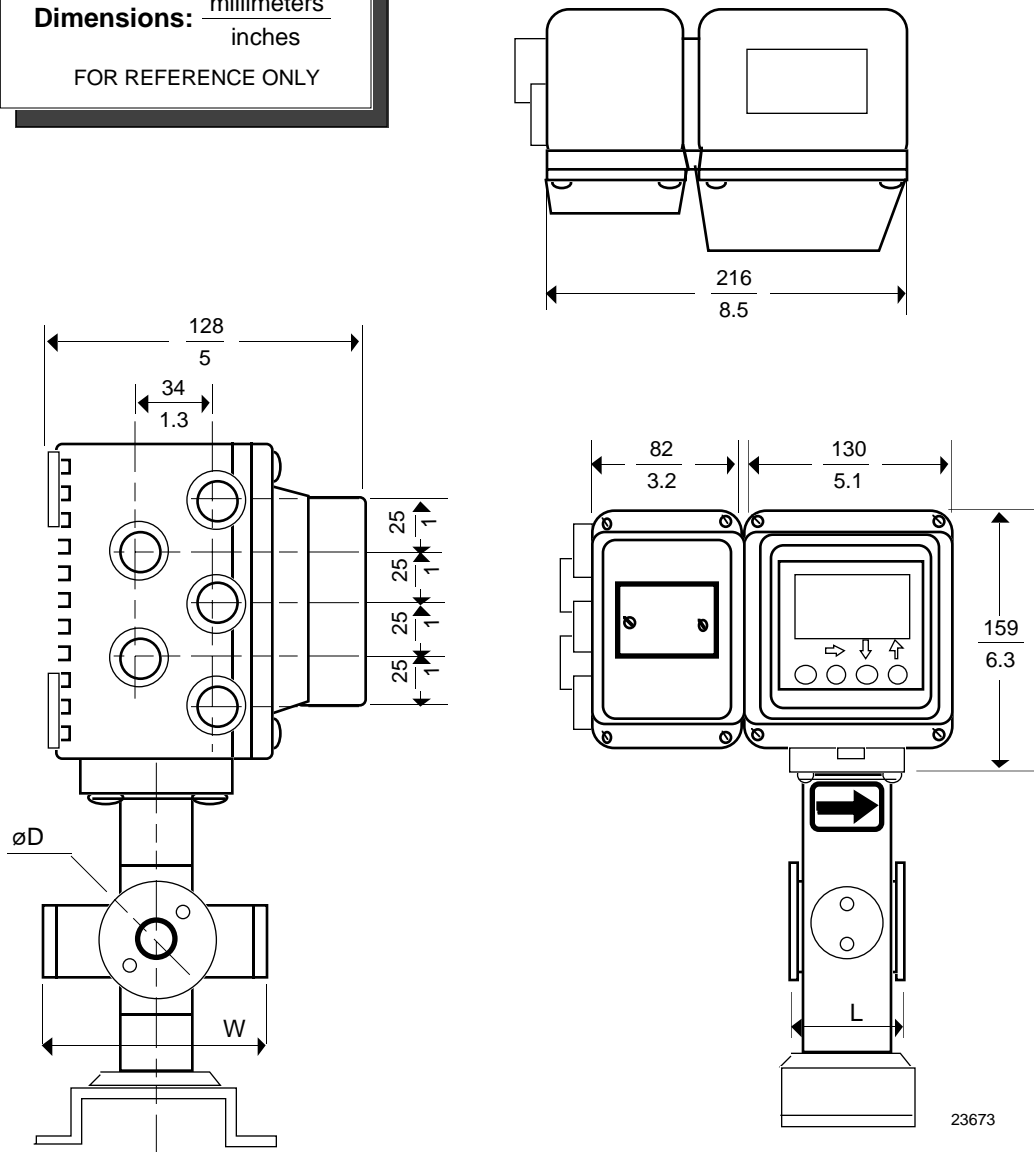
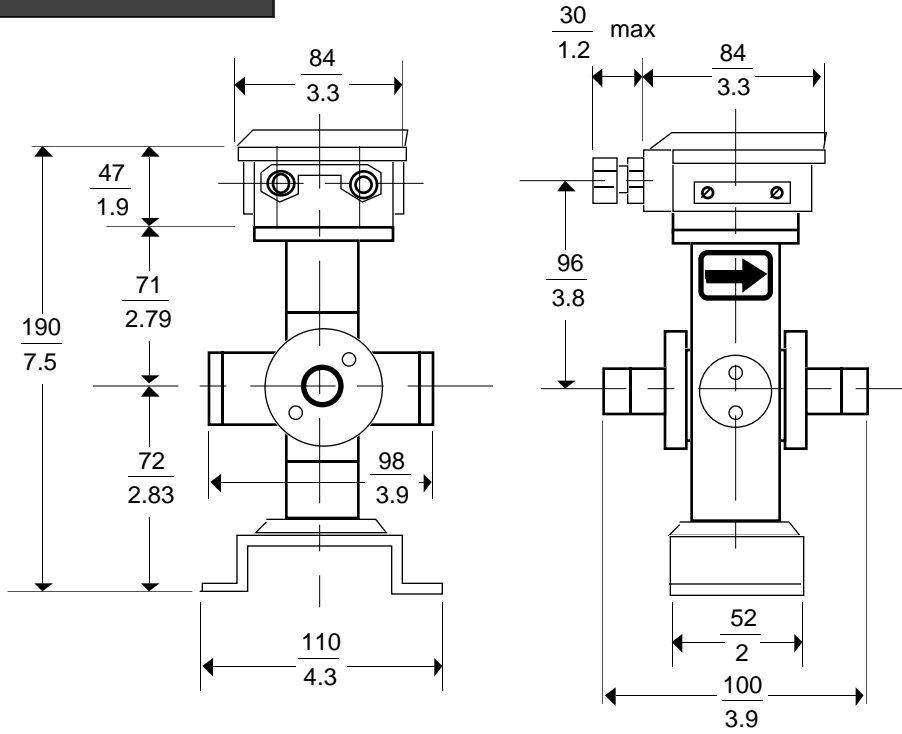

Figure 14—Dimensions for Integral Model—Refer to Table 8

Dimensions: $\frac{\text{millimeters}}{\text{inches}}$
 FOR REFERENCE ONLY



23457

Figure 15—Union Joint Dimensions – 2.5 mm to 15 mm (0.1 in. to 0.6 in.) Sizes

Dimensions: $\frac{\text{millimeters}}{\text{inches}}$
 FOR REFERENCE ONLY

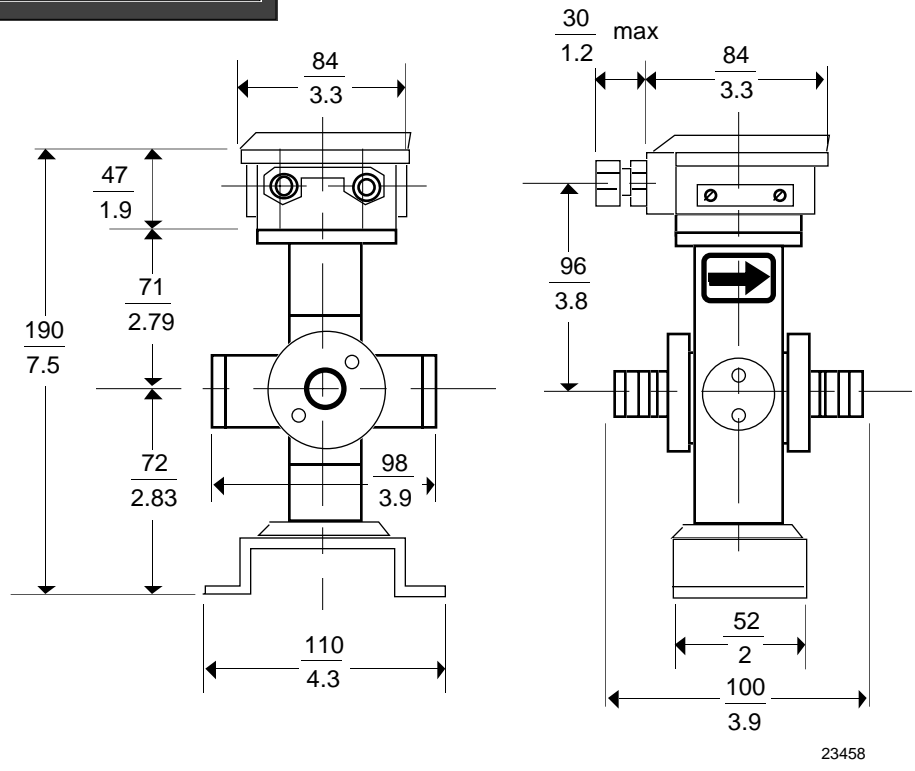

23458

Figure 16—Hose Joint Dimensions – 2.5 mm to 15 mm (0.1 in. to 0.6 in.) Sizes

Dimensions: $\frac{\text{millimeters}}{\text{inches}}$
 FOR REFERENCE ONLY

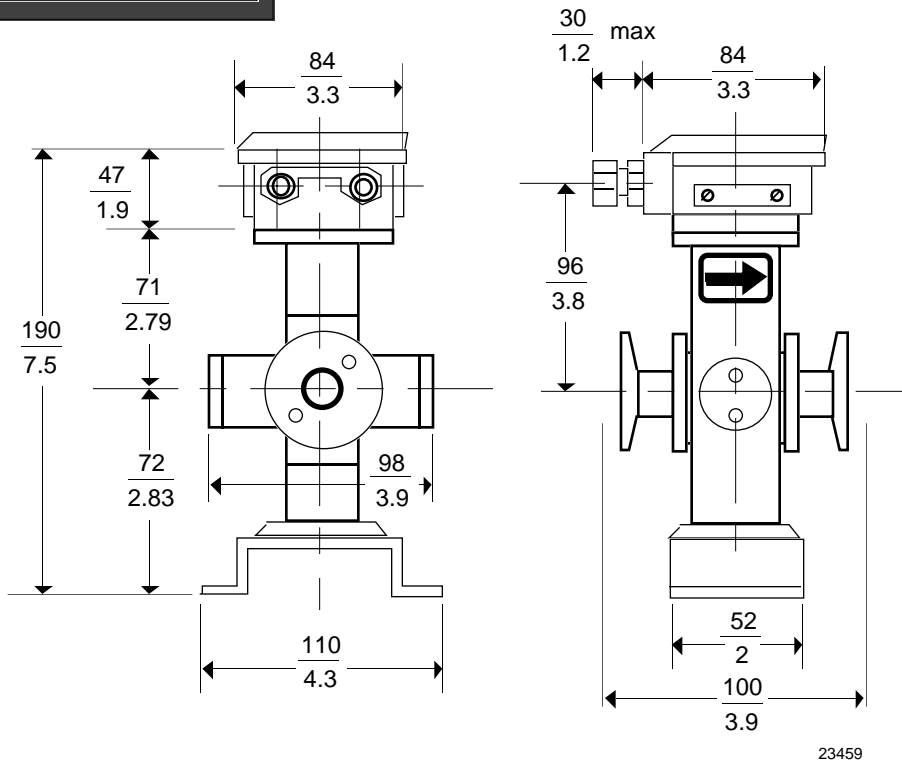
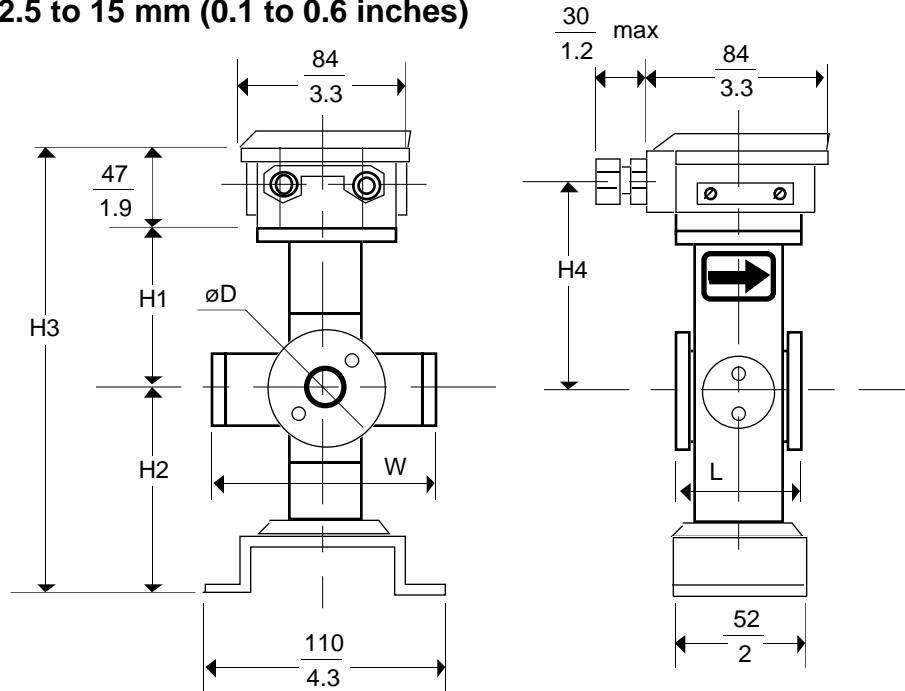

Figure 17—IDF/Tri-Clamp Dimensions – 2.5 mm to 15 mm (0.1 in. to 0.6 in.) Sizes

Dimensions: $\frac{\text{millimeters}}{\text{inches}}$
FOR REFERENCE ONLY

Sizes 2.5 to 15 mm (0.1 to 0.6 inches)



Sizes 25 to 200 mm (1 to 7.9 inches)

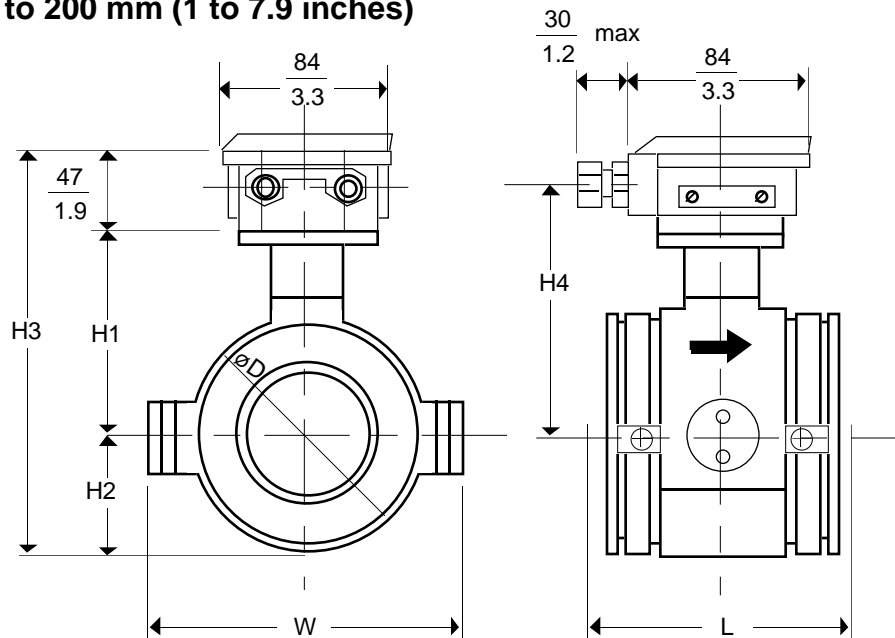

23460

Figure 18—Wafer Dimensions – 2.5 mm to 15 mm (0.1 in. to 0.6 in.) and 25mm to 200 mm (1 in. to 7.9 in.) Sizes—Refer to Table 8

Table 8—Dimensions for Figures 14 and 18

Detector Diameter mm (in.)	Face to Face Dimension mm (in.)	Height mm (in.)				Width mm (in.)	Outer Diameter mm (in.)	Inner Diameter mm (in.)	Wt kg
		L	H1	H2	H3				
2.5 (0.1)	56 (2.2)	71 (2.79)	72 (2.83)	190 (7.5)	96 (3.8)	98 (3.9)	49.5 (1.95)	2.5 ±0.2 (0.098 ±0.007)	2.6 (5.)
5 (0.2)	56 (2.2)	71 (2.79)	72 (2.83)	190 (7.5)	96 (3.8)	98 (3.9)	49.5 (1.95)	5 ±0.3 (0.196 ±0.011)	2.6 (5.)
10 (0.4)	56 (2.2)	71 (2.79)	72 (2.83)	190 (7.5)	96 (3.8)	98 (3.9)	49.5 (1.95)	10 ±0.5 (0.393 ±0.019)	2.6 (5.)
15 (0.6)	56 (2.2)	71 (2.79)	72 (2.83)	190 (7.5)	96 (3.8)	98 (3.9)	49.5 (1.95)	15 ±0.5 (0.590 ±0.019)	2.6 (5.)
25 (1)	56 (2.2)	77 (3)	34 (1.3)	158 (6.2)	102 (4)	106 (4.2)	68 (2.7)	24 ±0.5 (0.944 ±0.019)	2.6 (5.)
40 (1.6)	80 (3.2)	84 (3.3)	43.5 (1.7)	174.5 (6.9)	109 (4.3)	125 (5)	87 (3.4)	38.5 ±1 (1.515 ±0.039)	2.8 (6.)
50 (2)	86 (3.4)	93 (3.7)	52 (2)	192 (7.6)	118 (4.7)	135 (5.0)	104 (4.1)	50 ±1 (1.968 ±0.039)	3.4 (7.)
65 (2.6)	96 (3.8)	100 (4)	62 (2.4)	209 (8.2)	125 (5)	148 (5.8)	124 (4.9)	63 ±1 (2.480 ±0.039)	4.5 (9.)
80 (3.1)	106 (4.2)	108 (4.3)	67 (2.6)	222 (8.7)	133 (5.2)	164 (6.5)	134 (5.3)	75 ±2 (2.952 ±0.078)	5.2 (11)
100 (3.9)	120 (4.7)	120.5 (4.7)	79.5 (3.1)	247 (9.7)	145.5 (5.7)	189 (7.4)	159 (6.3)	100 ±2 (3.937 ±0.078)	6.7 (14)
125 (4.9)	140 (5.5)	133 (5.2)	95 (3.7)	275 (10.8)	158 (6.2)	214 (8.4)	190 (7.5)	123 ±3 (4.842 ±0.118)	10 (22)
150 (5.9)	160 (6.3)	160 (6.3)	110 (4.3)	317 (12.5)	240 (9.5)	240 (9.5)	220 (8.7)	147 ±3 (5.787 ±0.118)	13 (30)
200 (7.9)	200 (7.90)	185 (7.3)	135 (5.3)	367 (14.5)	210 (8.3)	290 (11.4)	270 (10.6)	195 ±3 (7.677 ±0.118)	22 (48)

Dimensions: $\frac{\text{millimeters}}{\text{inches}}$
 FOR REFERENCE ONLY

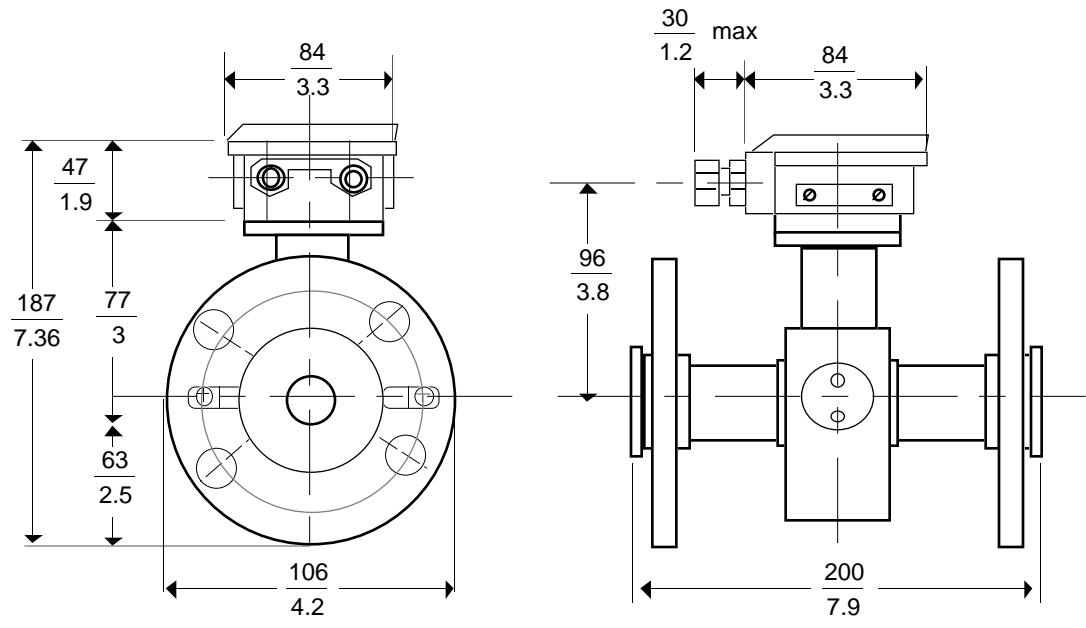

Inner diameter: $24 \pm 0.5 \text{ mm}$ ($0.944 \pm 0.019 \text{ in.}$)
Weight: 5.5 kg (12.1 lbs.)

23461

Figure 19—Flange Dimensions – 25 mm (1 in.) Sizes

Dimensions: $\frac{\text{millimeters}}{\text{inches}}$

FOR REFERENCE ONLY

Sizes 40 to 100 mm (1.6 to 3.4 inches)

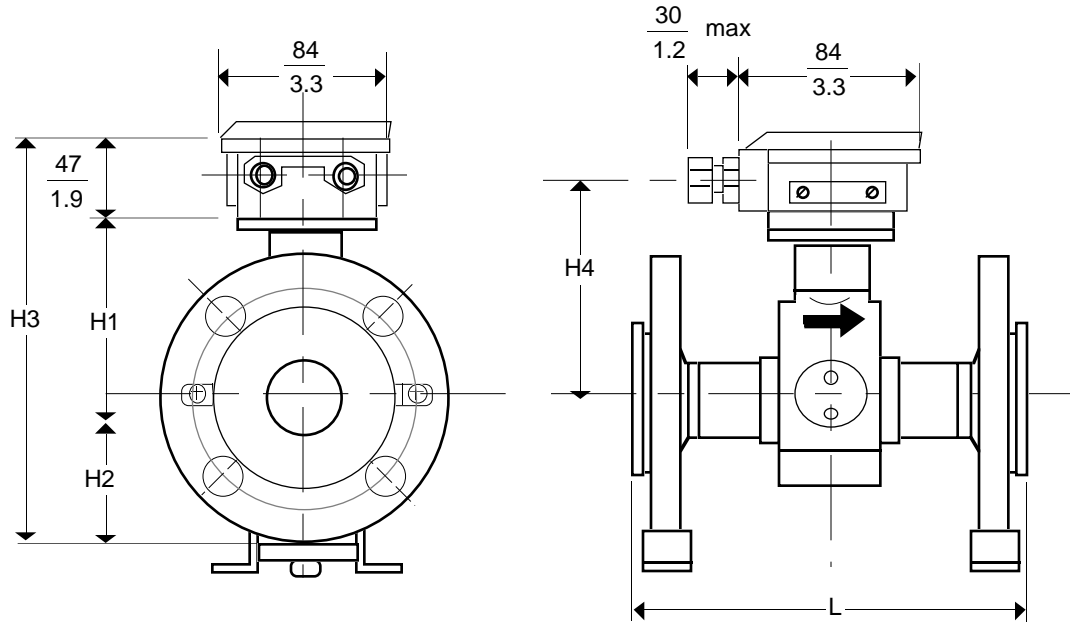

Sizes 150 to 600 mm (5.9 to 23.6 inches)

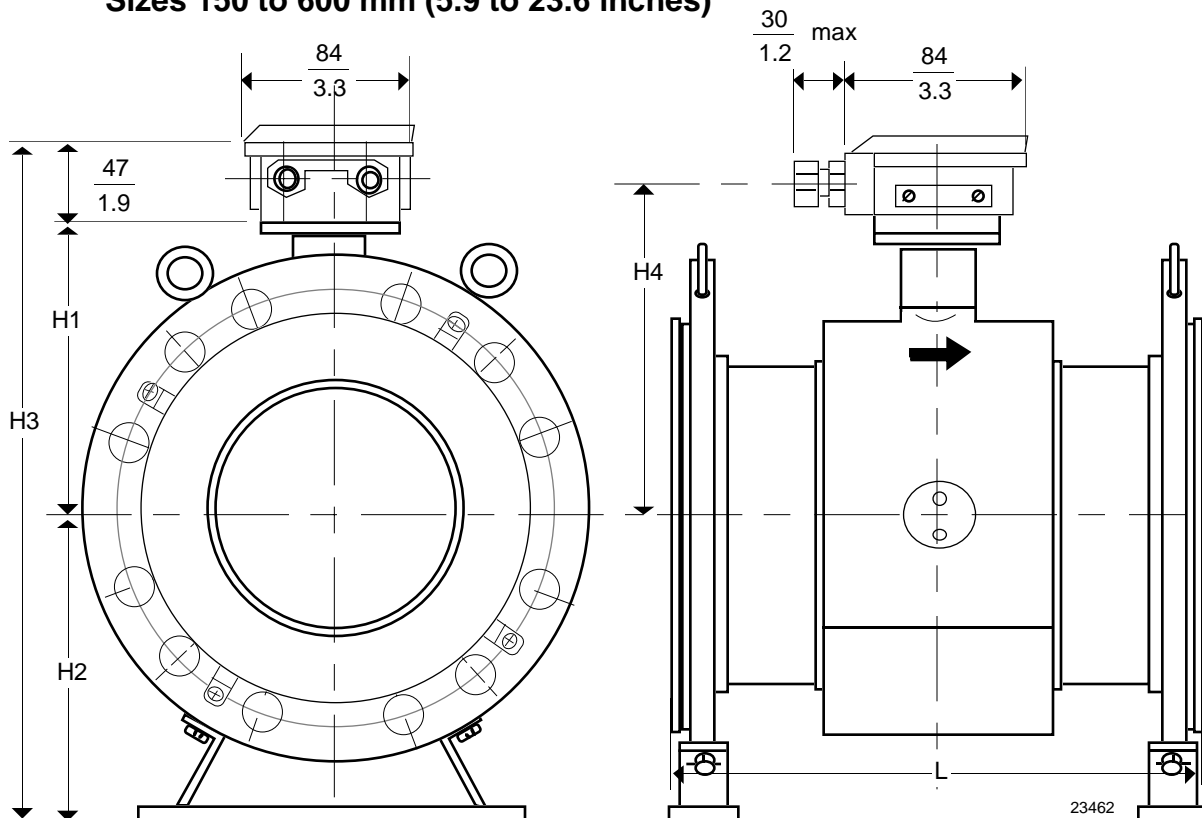

Figure 20—Flange Dimensions – 40 mm to 100 mm (1.6 in. to 3.9 in.) and 150 mm to 600 mm (5.9 in. to 23.6 in.) Sizes—Refer to Table 9

Table 9—Dimensions for Figure 20

Detector Diameter mm (in.)	Face to Face Dimension mm (in.)	Height mm (in.)				Inner Diameter mm (in.)	Weight kg (lbs)
		L	H1	H2	H3		
40 (1.6)	200 (7.9)	84 (3.3)	85 (3.35)	216 (8.5)	109 (4.3)	38.5 ±1 (1.515 ±0.039)	6.5 (14.3)
50 (2)	200 (7.9)	93 (3.7)	90 (3.5)	230 (9.1)	118 (4.7)	50 ±1 (1.968 ±0.039)	8.5 (18.7)
65 (2.6)	200 (7.9)	100 (3.9)	102 (4)	249 (9.8)	125 (4.9)	63 ±1 (2.480 ±0.039)	10 (22.1)
80 (3.1)	200 (7.9)	108 (4.3)	105 (4.1)	260 (10.2)	133 (5.2)	75 ±2 (2.952 ±0.078)	12.6 (27.8)
100 (3.9)	250 (9.8)	120.5 (4.7)	115 (4.5)	167.5 (6.6)	45.5 (5.7)	100 ±2 (3.937 ±0.078)	18.4 (40.6)
125 (4.9)	250 (9.8)	133 (5.2)	143 (5.6)	323 (12.7)	158 (6.2)	123 ±3 (4.842 ±0.118)	26 (57.3)
150 (5.9)	300 (11.8)	160 (6.3)	158 (6.2)	365 (14.4)	185 (7.3)	147 ±3 (5.787 ±0.118)	32.6 (71.9)
200 (7.9)	350 (13.8)	185 (7.3)	175 (7.1)	411 (16.2)	210 (8.3)	195 ±3 (7.677 ±0.118)	48 (105.8)
250 (9.8)	450 (17.7)	212 (8.3)	221 (8.7)	480 (18.9)	237 (9.3)	245 ±4 (9.645 ±0.157)	60 (132.3)
300 (11.8)	500 (19.7)	235 (9.3)	250 (9.8)	532 (20.9)	260 (10.2)	295 ±4 (11.614 ±0.167)	73 (160.9)
350 (13.8)	550 (21.7)	259 (10.2)	273 (10.8)	579 (22.8)	298 (11.7)	345 ±5 (13.582 ±0.196)	96 (211.6)
400 (15.8)	600 (23.6)	287 (11.3)	321 (12.6)	655 (25.8)	312 (12.3)	395 ±5 (15.551 ±0.196)	128 (282.2)
450 (17.7)	600 (23.6)	339 (13.3)	364 (14.3)	750 (29.5)	364 (14.3)	445 ±6 (17.519 ±0.236)	213 (469.5)
500 (19.7)	600 (23.6)	343 (13.5)	383 (15.1)	773 (30.4)	368 (14.5)	495 ±6 (19.488 ±0.236)	202 (445.3)
600 (23.6)	650 (25.6)	392 (15.4)	446 (17.6)	885 (34.8)	417 (16.4)	595 ±6 (23.425 ±0.236)	272 (599.6)

Ordering Data and Special Instructions

Refer to the following model selection guides to build the appropriate model numbers for the MagneW 3000 **PLUS** components that you need to meet your application requirements.

MagneW 3000 *PLUS* Integral Converter and Wafer Style Detector Model Selection Guide

Instructions

- Select the desired key number. The arrow to the right marks the selection available.
- Make one selection from Tables I thru III, using the column below the proper arrow. Select as many Table IV options as desired. (If no selections are desired, specify 00.) A dot (•) denotes unrestricted availability. A letter denotes restricted availability. Restrictions follow Table IV.
- A complete Model Number must have the designated number of digits in each table.

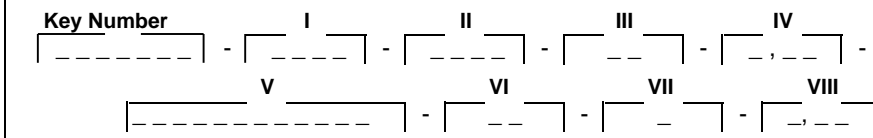

* = Stocked

KEY NUMBER

Description	Selection	Availability
MagneW 3000 <i>PLUS</i> Integral Converter and MGG 18D Wafer Style Detector	MGG14ID	↓

TABLE I

A - Power Supply			
AC100V 50/60Hz	- Refer to Factory for Delivery	A _ _ _	•
AC110V 50/60Hz	- Refer to Factory for Delivery	B _ _ _	•
AC115/120V-50/60Hz		C _ _ _	• *
AC200V 50/60Hz	- Refer to Factory for Delivery	D _ _ _	•
AC220V 50/60Hz	- Refer to Factory for Delivery	E _ _ _	•
AC230/240V 50/60Hz		F _ _ _	•
DC24V (Noise Filter 50Hz)		G _ _ _	•
DC24V (Noise Filter 60Hz)		H _ _ _	•
B - Output Signal/Communication			
Volume Flow 4-20mA DC Output/without Communication (Active 4-20)		_ A _ _	•
Volume Flow 4-20mA DC Output/with Communication (Passive 4-20)		_ B _ _	• *
Volume Flow DE Output/with Communication		_ C _ _	•
Volume Flow Fieldbus Output/with Communication	Note 1	_ F _ _	k
Volume Flow HART Protocol Output/with Communication		_ H _ _	•
C - Conduit Connection/Watertight Gland			
G1/2 Internal Thread/without Watertight Gland	Not CSA/FM Approved	_ _ 1 _	•
G1/2 Internal Thread/with brass (Ni-plated) Watertight Gland	Not CSA/FM Approved	_ _ 2 _	•
G1/2 Internal Thread/with Plastic Watertight Gland	Not CSA/FM Approved	_ _ 3 _	•
1/2 NPT Internal Thread/without Watertight Gland	CSA FM Approved	_ _ 4 _	• *
CM20 Internal Thread/without Watertight Gland	Not CSA/FM Approved	_ _ 5 _	•
Pg13.5 Internal Thread/without Watertight Gland	Not CSA/FM Approved	_ _ 6 _	•
G1/2 Internal Thread/with SUS304 Watertight Gland	Not CSA/FM Approved	_ _ 7 _	•
D - Installation/Wiring Direction			
Horizontal Piping Mounting/Upstream Side		_ _ _ A	• *
Horizontal Piping Mounting/Downstream Side		_ _ _ B	•
Horizontal Piping Mounting/Left Side Viewed from Upstream		_ _ _ C	•

Availability
MGG14ID
Selection ↘

TABLE I (continued)

D - Installation/Wiring Direction (continued)		
Horizontal Piping Mounting/Right Side View from Upstream	___ D	•
Vertical Piping Mounting/Downstream Side (flow direction downstream to upstream)	___ E	•
Vertical Piping Mounting/Downstream Side (flow direction upstream to downstream)	___ F	•

TABLE II

A - Finish		
Standard	X ___	• *
Corrosion-Resistant Finish	1 ___	•
Corrosion-Proof Finish	2 ___	•
B - Display		
None	_ X _	•
Main Display: Instantaneous Indication of Flow Volume in %	_ A _	•
Main Display: Instantaneous Indication of Actual Flow Volume	_ B _	• *
Main Display: Indication of Integrated Flow Volume (need pulse output board) Note 2	_ C _	m
C - Contact Inputs/Outputs		
None	_ X _	•
1 Input and 1 Output (ranging function, warning for contact input/output, etc.) Note 3	_ 1 _	n
2 Inputs (ranging function, external automatic zero adjustment input, etc.) Note 3	_ 2 _	p
2 Outputs (ranging function, warning for contact outputs) Note 3	_ 3 _	r
D - Style Code		
None	___ X	• *

TABLE III

A - Version		
Honeywell Version (indication other than SI units)	SH	• *

TABLE IV

A - Options		
Empty Pipe Detection Function	A	• *
Pulse Output (open collector)	B	•
Traceability Certificate	C	•
Polycarbonate Window	G	•
Attachment of Tagplate to the Terminal Box Note 4	J	•
Specific Color Finish Note 5	L	•
Ranging Functions - See Chart for Availability		
Automatic switching dual range	F1	s
External ranges switching	F2	t
Direct/reverse automatic ranges	F3	s
Direct/reverse external switching	F4	t

} b

Availability

MGG14ID
Selection

TABLE V

A - Diameter		Flow Range Minimum		Flow Range Maximum		MGG14ID Selection	Availability
Millimeter	Inches	In US GPM	In Litres	In US GPM	In Litres		
2.5	0.1	0.008	0.03	0.779	2.95	002	•
5.0	0.2	0.031	0.12	3.113	11.78	005	•
10	0.39	0.125	0.47	12.460	47.17	010	•
15	0.5	0.280	1.06	28.002	106.00	015	•
25	1.0	0.779	2.95	77.931	295.00	025	•
40	1.5	1.990	7.53	199.011	753.34	040	•
50	2.0	3.113	11.78	311.285	1178.34	050	•
65	2.5	5.239	19.83	523.945	1983.34	065	•
80	3.0	7.969	30.17	796.924	3016.68	080	•
100	4.0	12.46	47.17	1246.02	4716.68	100	•
125	5.0	19.46	73.67	1946.08	7366.69	125	•
150	6.0	28.00	106.00	2800.24	10600.04	150	•
200	8.0	49.80	188.50	4979.68	18850.07	200	•
B - Liner							
PFA						--- P ---	• *
Polyurethane Rubber (25 to 200mm only)						--- Q ---	d
C - Pipe Connection							
Wafer JIS10K						--- 11 ---	j
Wafer JIS20K						--- 12 ---	j
Wafer JIS30K						--- 13 ---	j
Wafer JIS10/20K for 10mm flange						--- 14 ---	g
Wafer JIS30K for 10mm flange						--- 15 ---	g
Wafer ANSI150						--- 21 ---	• *
Wafer ANSI300						--- 22 ---	•
Wafer JIS G3451 F12 (diameter 80mm or larger)						--- 31 ---	h
Wafer DIN PN10						--- 41 ---	j
Wafer DIN PN16						--- 42 ---	j
Wafer DIN PN25						--- 43 ---	j
Wafer DIN PN40						--- 44 ---	j
Wafer DIN PN10/16/25/40 for 10mm flange						--- 45 ---	g
Wafer JPI150						--- 61 ---	•
Wafer JPI300						--- 62 ---	•
D - Electrodes							
SUS316L						--- L ---	• *
Hastelloy C (with Teflon PFA only)						--- C ---	c
Titanium						--- K ---	•
Zirconium (with Teflon PFA only)						--- H ---	c
Tantalum (with Teflon PFA only)						--- T ---	c
Tungsten Carbide (only for size 10mm and above)						--- W ---	e
Platinum-Iridium (with Teflon PFA only)						--- P ---	c
Alloy 20 (with Teflon PFA only)						--- A ---	c
Hastelloy B (with Teflon PFA only)						--- B ---	c
SUS304 (with Teflon PFA only)						--- E ---	c
Monel (with Teflon PFA only)						--- M ---	c
Nickel (with Teflon PFA 15-200mm only)						--- N ---	f
SUS316L Protruded Tip (with Teflon PFA 15-200mm only)						--- 1 ---	f
SUS316L for Alumina with Flat Tip (with Teflon PFA 15-200mm only)						--- 2 ---	f
SUS316L for Alumina with Pointed Tip (with Teflon PFA 15-200mm only)						--- 3 ---	f

Availability

MGG14ID
Selection

TABLE V (continued)

	MGG14ID Selection	Availability
E - Grounding Rings		
SUS316	----- S -----	• *
SS Top Hat Style (Upstream Only)	----- G -----	c
Hastelloy C (with Teflon PFA only)	----- C -----	c
Titanium	----- K -----	•
Zirconium (with Teflon PFA only)	----- H -----	c
Tantalum (with Teflon PFA only)	----- T -----	c
Platinum (with Teflon PFA only)	----- P -----	c
Alloy 20	----- A -----	c
Hastelloy B	----- B -----	c
SUS304	----- E -----	c
SUS316L	----- L -----	c
Nickel	----- N -----	c
F - Wiring Connection/Water Tight Gland		
Integral Type	----- 1 -----	• *
G - Face to Face Dimension		
Standard	----- A -----	• *
Competitive (Refer to Table 103 and Consult Factory)	----- 9 -----	c
H - Installation/Wiring Direction		
Integral Type	----- H -----	• *
I - Calibration		
Standard Calibration - 2 Point (0, 100%) w/ Master Converter	----- R -----	• *
3 Point (0, 50, 100%) with Master Converter	----- P -----	•
5 Point (0, 25, 50, 75, 100%) with Master Converter	----- Q -----	•
2 Point (0, 100%) with Customer's Specific Converter	----- J -----	•
3 Point (0, 50, 100%) with Customer's Specific Converter	----- A -----	•
5 Point (0, 25, 50, 75, 100%) with Customer's Specific Converter	----- E -----	•

TABLE VI

A - Finish		
Standard	X _	• *
Corrosion-resistant Finish	1 _	•
Corrosion-proof Finish	2 _	•
B - Bolts/Nuts		
None	_ X	• *
Carbon Steel	_ 1	•
SUS304	_ 2	•

Availability
MGG14ID
Selection ↓

TABLE VII

Version		
Standard	S	• *

TABLE VIII

Options		
Calibration Certificate (additional copy)	A	•
Traceability Certificate	B	•
Mill Sheet (only for electrodes and grounding rings)	C	•
Gasket for Plastic Piping	J	•
Attachment of Tagplate to Detector Terminal Box (Note 4)	K	•
Attachment of Tagplate to Neck of Detector (Note 4)	L	•
Specific Color Finish (Note 5)	P	•

Notes

- 1 Not available with 4 "B".
- 2 Option "B" must be selected.
- 3 Observing restriction, please specify required F1-F4 codes from table below.
- 4 Must be selected if Tag number is required.
- 5 Order must specify Munsell color number.
- 5 Must be selected if Tag number is required.

Code	Ranging Functions	1 Input/Output	2 Inputs	2 Outputs
	• : Available Selection	1	2	3
F1	Automatic Switching Dual Range	•		•
F2	External Ranges Switching	•	•	
F3	Direct/Reverse Automatic Ranges	•		•
F4	Direct/Reverse External Switching	•	•	

RESTRICTIONS

Restriction		Available Only With	Not Available With	
Letter	Table	Selection	Table	Selection
b		Select only one from this group.		
c	VB	___ P		
d			VA	002, 005, 010
e			VA	002, 005
f	VB	___ P	VA	002, 005, 010
g	VA	10		
h	VA	080, 100, 125, 150, 200		
j			VA	010
k			IV	B
m	IV	B		
n	IV	F1, F2, F3, F4		
p	IV	F2, F4		
r	IV	F1, F3		
s	2C	__ 1, __ 3		
t	2C	__ 1, __ 3		

MagneW 3000 *PLUS* Integral Converter and Flanged Style Detector Model Selection Guide

Instructions

- Select the desired key number. The arrow to the right marks the selection available.
 - Make one selection from Tables I thru III, using the column below the proper arrow. Select as many Table IV options as desired. (If no selections are desired, specify 00.) A dot (•) denotes unrestricted availability. A letter denotes restricted availability. Restrictions follow Table IV.
 - A complete Model Number must have the designated number of digits in each table.
- Key Number**

I
II
III
IV

V
VI
VII
VIII

* = Stocked

KEY NUMBER	Selection	Availability
Description		
MagneW 3000 <i>PLUS</i> Integral Converter and MGG18F Flange Style Detector	MGG14IF	↓

TABLE I

A - Power Supply		
AC100V 50/60Hz	- Refer to Factory for Delivery	A _ _ _
AC110V 50/60Hz	- Refer to Factory for Delivery	B _ _ _
AC115/120V-50/60Hz		C _ _ _
AC200V 50/60Hz	- Refer to Factory for Delivery	D _ _ _
AC220V 50/60Hz	- Refer to Factory for Delivery	E _ _ _
AC230/240V 50/60Hz		F _ _ _
DC24V (Noise Filter 50Hz)		G _ _ _
DC24V (Noise Filter 60Hz)		H _ _ _
B - Output Signal/Communication		
Volume Flow 4-20mA DC Output/without Communication	(Active 4-20)	_ A _ _
Volume Flow 4-20mA DC Output/with Communication	(Passive 4-20)	_ B _ _
Volume Flow DE Output/with Communication		_ C _ _
Volume Flow Fieldbus Output/with Communication	Note 1	_ F _ _
Volume Flow HART Protocol Output/with Communication		_ H _ _
C - Conduit Connection/Watertight Gland		
G1/2 Internal Thread/without Watertight Gland	Not CSA/FM approved	_ _ 1 _
G1/2 Internal Thread/with brass (Ni-plated) Watertight Gland	Not CSA/FM approved	_ _ 2 _
G1/2 Internal Thread/with Plastic Watertight Gland	Not CSA/FM approved	_ _ 3 _
1/2 NPT Internal Thread/without Watertight Gland	CSA/FM NI approved	_ _ 4 _
CM20 Internal Thread/without Watertight Gland	Not CSA/FM approved	_ _ 5 _
Pg13.5 Internal Thread/without Watertight Gland	Not CSA/FM approved	_ _ 6 _
G1/2 Internal Thread/with SUS304 Watertight Gland	Not CSA/FM approved	_ _ 7 _
D - Installation/Wiring Direction		
Horizontal Piping Mounting/Upstream Side		_ _ _ A
Horizontal Piping Mounting/Downstream Side		_ _ _ B
Horizontal Piping Mounting/Left Side Viewed from Upstream		_ _ _ C

Availability

MGG14IF
Selection

TABLE I (continued)

D - Installation/Wiring Direction (continued)		
Horizontal Piping Mounting/Right Side View from Upstream	___ D	•
Vertical Piping Mounting/Downstream Side (flow direction downstream to upstream)	___ E	•
Vertical Piping Mounting/Downstream Side (flow direction upstream to downstream)	___ F	•

TABLE II

A - Finish			
Standard	X ___	•	*
Corrosion-Resistant Finish	1 ___	•	
Corrosion-Proof Finish	2 ___	•	
B - Display			
None	_ X _	•	
Main Display: Instantaneous Indication of Flow Volume in %	_ A _	•	*
Main Display: Instantaneous Indication of Actual Flow Volume	_ B _	•	
Main Display: Indication of Integrated Flow Volume (need pulse output board)	_ C _	e	
Note 2			
C - Contact Inputs/Outputs			
None	_ X _	•	*
1 Input and 1 Output (ranging function, warning for contact input/output, etc.)	_ 1 _	g	
Note 3			
2 Inputs (ranging function, external automatic zero adjustment input, etc.)	_ 2 _	j	
Note 3			
2 Outputs (ranging function, warning for contact outputs)	_ 3 _	k	
Note 3			
D - Style Code			
None	___ X	•	*

TABLE III

A - Version			
Honeywell Version (indication other than SI units)	SH	•	*

TABLE IV

A - Options				
Empty Pipe Detection Function	A	•	*	
Pulse Output (open collector)	B	•		
Traceability Certificate	C	•		
Polycarbonate Window	G	•		
Attachment of Tagplate to the Terminal Box	J	•		
Note 4				
Specific Color Finish	L	•		
Note 5				
Ranging Functions				
Automatic switching dual range	F1	n	b	
External ranges switching	F2	r		
Direct/reverse automatic ranges	F3	n		
Direct/reverse external switching	F4	r		

Code	Ranging Functions	1 Input/Output	2 Inputs	2 Outputs
	• : Available Selection	1	2	3
F1	Automatic Switching Dual Range	•		•
F2	External Ranges Switching	•	•	
F3	Direct/Reverse Automatic Ranges	•		•
F4	Direct/Reverse External Switching	•	•	

Availability

MGG14IF

Selection



TABLE V

A - Diameter		Flow Range Minimum		Flow Range Maximum		Selection	Availability
Millimeter	Inches	In US GPM	In Litres	In US GPM	In Litres		
25	1.0	0.779	2.95	77.931	295.00	025 _____	•
40	1.5	1.990	7.53	199.011	753.34	040 _____	•
50	2.0	3.113	11.78	311.285	1178.34	050 _____	•
65	2.5	5.239	19.83	523.945	1983.34	065 _____	•
80	3.0	7.969	30.17	796.924	3016.68	080 _____	•
100	4.0	12.46	47.17	1246.02	4716.68	100 _____	•
125	5.0	19.46	73.67	1946.08	7366.69	125 _____	•
150	6.0	28.00	106.00	2800.24	10600.04	150 _____	•
200	8.0	49.80	188.50	4979.68	18850.07	200 _____	•
B - Liner							
PFA						___ P _____	• *
Polyurethane Rubber (25 to 200mm only)						___ Q _____	•
C - Pipe Connection				Flange Material			
Flange JIS10K				Standard		___ J11 _____	•
Flange JIS20K				Standard		___ J21 _____	•
Flange JIS30K				Standard		___ J31 _____	•
Flange ANSI 150				Standard		___ A11 _____	• *
Flange ANSI 300				Standard		___ A21 _____	•
Flange JIS G3451 F12 (diameter 80mm or larger)				Standard		___ G11 _____	h
Flange DIN PN10				Standard		___ D11 _____	•
Flange DIN PN16				Standard		___ D21 _____	•
Flange DIN PN25				Standard		___ D31 _____	•
Flange DIN PN40				Standard		___ D41 _____	•
Flange JPI 150				Standard		___ P11 _____	•
Flange JPI 300				Standard		___ P21 _____	•
Flange JIS 10K (diameter 80mm or larger)				SUS304		___ J14 _____	m
Flange JIS 20K (diameter 80mm or larger)				SUS304		___ J24 _____	m
Flange JIS 30K (diameter 80mm or larger)				SUS304		___ J34 _____	m
Flange ANSI 150 (diameter 80mm or larger)				SUS304		___ A14 _____	m
Flange ANSI 300 (diameter 80mm-450mm only)				SUS304		___ A24 _____	m
Flange JIS G3451 F12 (diameter 80mm or larger)				SUS304		___ G14 _____	m
Flange DIN PN10 (diameter 80mm or larger)				SUS304		___ D14 _____	m
Flange DIN PN16 (diameter 80mm or larger)				SUS304		___ D24 _____	m
Flange DIN PN25 (diameter 80mm or larger)				SUS304		___ D34 _____	m
Flange DIN PN40 (diameter 80mm or larger)				SUS304		___ D44 _____	m
Flange JPI150 (diameter 80mm or large)				SUS304		___ P14 _____	m
Flange JPI300 (diameter 80mm or larger)				SUS304		___ P24 _____	m

TABLE V (continued)

Availability
MGG14IF
Selection ↓

D - Electrodes				
SUS316L		----- L -----	•	*
Hastelloy C	(with Teflon PFA only)	----- C -----	c	
Titanium		----- K -----	•	
Zirconium	(with Teflon PFA only)	----- H -----	c	
Tantalum	(with Teflon PFA only)	----- T -----	c	
Tungsten Carbide		----- W -----	•	
Platinum-Iridium	(with Teflon PFA only)	----- P -----	c	
Alloy 20	(with Teflon PFA only)	----- A -----	c	
Hastelloy B	(with Teflon PFA only)	----- B -----	c	
SUS304	(with Teflon PFA only)	----- E -----	c	
Monel	(with Teflon PFA only)	----- M -----	c	
Nickel	(with Teflon PFA only)	----- N -----	c	
SUS316L Protruded Tip	(with Teflon PFA only)	----- 1 -----	c	
SUS316L for Alumina with Flat Tip	(with Teflon PFA only)	----- 2 -----	c	
SUS316L for Alumina with Pointed Tip	(with Teflon PFA only)	----- 3 -----	c	
E - Grounding Rings				
SUS316		----- S -----	•	*
SS Top Hat Style (Upstream Only)		----- G -----	•	
Hastelloy C	(with Teflon PFA only)	----- C -----	c	
Titanium		----- K -----	•	
Zirconium	(with Teflon PFA only)	----- H -----	c	
Tantalum	(with Teflon PFA only)	----- T -----	c	
Platinum	(with Teflon PFA only)	----- P -----	c	
Alloy 20	(with Teflon PFA only)	----- A -----	c	
Hastelloy B	(with Teflon PFA only)	----- B -----	c	
SUS304	(with Teflon PFA only)	----- E -----	c	
SUS316L	(with Teflon PFA only)	----- L -----	c	
Nickel	(with Teflon PFA only)	----- N -----	c	
SS Top Hat Style (Upstream Only)		----- G -----	c	
F - Wiring Connection/Watertight Gland				
Integral Type		----- 1 -----	•	*
G - Face to Face Dimension				
Standard		----- A -----	•	*
Competitive	(refer to Table 103 and consult factory)	----- 9 -----	c	
H - Installation/Wiring Direction				
Integral Type		----- H -----	•	*
I - Calibration				
Standard Calibration - 2 Point (0, 100%) w/ Master Converter		----- R -----	•	*
3 Point (0, 50, 100%) with Master Converter		----- P -----	•	
5 Point (0, 25, 50, 75, 100%) with Master Converter		----- Q -----	•	
2 Point (0, 100%) with Customer's Specific Converter		----- J -----	•	
3 Point (0, 50, 100%) with Customer's Specific Converter		----- A -----	•	
5 Point (0, 25, 50, 75, 100%) with Customer's Specific Converter		----- E -----	•	

Availability

MGG14IF

Selection



TABLE VI

A - Finish		
Standard	X	• *
Corrosion-resistant Finish	1	•
Corrosion-proof Finish	2	•

TABLE VII

Version		
Standard	S	• *

TABLE VIII

Options		
Calibration Certificate (additional copy)	A	•
Traceability Certificate	B	•
Mill Sheet (only for electrodes and grounding rings)	C	•
Gasket for Plastic Piping	J	•
Attachment of Tagplate to Detector Terminal Box (Note 4)	K	•
Attachment of Tagplate to Neck of Detector (Note 4)	L	•
Specific Color Finish (Note 5)	P	•

Note 1: Not available with Option B, Table IV.

Note 2: Available only with Table IV B.

Note 3: Observing restriction, please specify required F1-F4 codes from Table below.

Note 4: Must be selected if Tag number is required.

Note 5: Order must specify Munsell color number.

RESTRICTIONS

Restriction		Available Only With		Not Available With
Letter	Table	Selection	Table	Selection
b		Select only one option from this group.		
c	VB	___ P		
e	IV	B		
f			IV	B
g	IV	F1, F2, F3, F4		
h			VA	025, 040, 050, 065
j	IV	F2, F4		
k	IV	F1, F3		
m	VA	080, 100, 125, 150, 200		
	VB	__ P		
n	IIC	__ 1, __ 3		
r	IIC	__ 1, __ 2		

MagneW 3000 *PLUS* Remote Converter Model Selection Guide

Instructions

- Select the desired key number. The arrow to the right marks the selection available.
- Make one selection from Tables I thru III, using the column below the proper arrow. Select as many Table IV options as desired. (If no selections are desired, specify 00.) A dot (•) denotes unrestricted availability. A letter denotes restricted availability. Restrictions follow Table IV.
- A complete Model Number must have the designated number of digits in each table.

Key Number I II III IV
 [] - [] - [] - [] - []

* = Stocked

KEY NUMBER	Selection	Availability
Description		
MagneW 3000 <i>PLUS</i> Remote Converter	MGG14C	↓

TABLE I

A - Power Supply			
AC100V 50/60Hz	- Refer to Factory for Delivery	A _ _ _	•
AC110V 50/60Hz	- Refer to Factory for Delivery	B _ _ _	•
AC115/120V 50/60Hz		C _ _ _	• *
AC200V 50/60Hz	- Refer to Factory for Delivery	D _ _ _	•
AC220V 50/60Hz	- Refer to Factory for Delivery	E _ _ _	•
AC230/240V 50/60Hz		F _ _ _	f
DC24V (Noise Filter 50Hz)		G _ _ _	•
DC24V (Noise Filter 60Hz)		H _ _ _	•
B - Output Signal/Communication			
Volume Flow 4-20mA DC Output/without Communication	(Active 4-20)	_ A _ _	•
Volume Flow 4-20mA DC Output/with Communication	(Passive 4-20)	_ B _ _	• *
Volume Flow DE Output/with Communication		_ C _ _	•
Volume Flow Fieldbus Output/with Communication	Note 1	_ F _ _	•
Volume Flow HART Protocol Output/with Communication		_ H _ _	•
C - Conduit Connection/Watertight Gland			
G1/2 Internal Thread/without Watertight Gland (Not CSA/FM approved)		_ _ 1 _	
G1/2 Internal Thread/with brass (Ni-plated) Watertight Gland (Not CSA/FM approved)		_ _ 2 _	•
G1/2 Internal Thread/with Plastic Watertight Gland (Not CSA/FM approved)		_ _ 3 _	•
1/2 NPT Internal Thread/without Watertight Gland (CSA/FM approved)		_ _ 4 _	• *
CM20 Internal Thread/without Watertight Gland (Not CSA/FM approved)		_ _ 5 _	•
Pg13.5 Internal Thread/without Watertight Gland (Not CSA/FM approved)		_ _ 6 _	•
G1/2 Internal Thread/with SUS304 Watertight Gland (Not CSA/FM approved)		_ _ 7 _	•
D - Installation/Wiring Direction			
Wall Mounting with Standard Bracket		_ _ _ G	•
2B Pipe Mounting with Standard Bracket		_ _ _ H	•
Without Mounting Bracket		_ _ _ X	• *

		Availability	
		MGG14C Selection	↓
TABLE II			
A - Finish			
Standard	X _ _ _	•	*
Corrosion-Resistant Finish	1 _ _ _	•	
Corrosion-Proof Finish	2 _ _ _	•	
B - Display			
None	_ X _ _	•	*
Main Display: Instantaneous Indication of Flow Volume in %	_ A _ _	•	
Main Display: Instantaneous Indication of Actual Flow Volume	_ B _ _	•	
Main Display: Indication of Integrated Flow Volume (need pulse output board) Note 2	_ C _ _	e	
C - Contact Inputs/Outputs			
None	_ _ X _	•	*
1 Input and 1 Output (ranging function, warning for contact input/output, etc.) Note 3	_ _ 1 _	g	
2 Inputs (ranging function, external automatic zero adjustment input, etc.) Note 3	_ _ 2 _	h	
2 Outputs (ranging function, warning for contact outputs) Note 3	_ _ 3 _	j	
D - Style Code			
None	_ _ _ X	•	*

TABLE III				
A - Version				
Honeywell Version	(indication other than SI units)	SH	•	*

TABLE IV				
A - Options				
Empty Pipe Detection Function		A	•	*
Pulse Output (open collector)		B	•	
Traceability Certificate		C	•	
Polycarbonate Window		G	•	
Attachment of Tagplate to the Terminal Box Note 4		J	•	
Specific Color Finish Note 5		L	•	
Ranging Functions Note 6				
Automatic switching dual range		F1	c	b
External ranges switching		F2	d	
Direct/reverse automatic ranges		F3	c	
Direct/reverse external switching		F4	d	

Code	Ranging Functions	1 Input/Output	2 Inputs	2 Outputs
	• : Available Selection	1	2	3
F1	Automatic Switching Dual Range	•		•
F2	External Ranges Switching	•	•	
F3	Direct/Reverse Automatic Ranges	•		•
F4	Direct/Reverse External Switching	•	•	

Notes

- 1 Not available with Option "B".
- 2 Option "B" must be selected.
- 3 Observing restriction, please specify required F1-F4 codes from table below.
- 4 Must be selected if Tag number is required.
- 5 Order must specify Munsell color number.
- 6 Refer to Chart for Range Functions Restrictions.

RESTRICTIONS

Restrictions Letter										Available Only With		Not Available With	
b	c	d	e	f	g	h	j	Table	Selection	Table	Selection		
	■							IIC	-- 1, -- 3				
		■						IIC	-- 1, -- 2				
			■					IV	B				
				■						IV	B		
					■			IV	F1, F2, F3, F4				
						■		IV	F2, F4				
							■	IV	F1, F3				
■								Select only one from this group					

MagneW 3000 PLUS Remote Detector Wafer Type, Size 2.5-200mm

Model Selection Guide

Instructions

- Select the desired key number. The arrow to the right marks the selection available.
- Make one selection from Tables I thru III, using the column below the proper arrow. Select as many Table IV options as desired. (If no selections are desired, specify 00.) A dot (•) denotes unrestricted availability. A letter denotes restricted availability. Restrictions follow Table IV.
- A complete Model Number must have the designated number of digits in each table.

Key Number I II III IV
 [] - [] - [] - [] - []

* = Stocked

KEY NUMBER	Selection	Availability
Description MagneW 3000 PLUS Remote Detector, Wafer Type, Sizes 2.5-200mm CSA FM SP Approved CL I, Div.1, Groups B-G	MGG17D	↓

TABLE I

A - Diameter		Flow Range Minimum		Flow Range Maximum			
Millimeter	Inches	In US GPM	In Litres	In US GPM	In Litres		
2.5	0.1	0.008	0.03	0.779	2.95	002	•
5.0	0.2	0.031	0.12	3.113	11.78	005	•
10	0.39	0.125	0.47	12.460	47.17	010	•
15	0.5	0.28	1.06	28.002	106.00	015	•
25	1.0	0.779	2.95	77.931	295.00	025	•
40	1.5	1.99	7.53	199.011	753.34	040	•
50	2.0	3.113	11.78	311.285	1178.34	050	•
65	2.5	5.239	19.83	523.945	1983.34	065	•
80	3.0	7.969	30.17	796.924	3016.68	080	•
100	4.0	12.46	47.17	1246.02	4716.68	100	•
125	5.0	19.46	73.67	1946.08	7366.69	125	•
150	6.0	28	106.00	2800.24	10600.04	150	•
200	8.0	49.8	188.50	4979.68	18850.07	200	•
B - Liner							
PFA						--- P ---	• * d
Polyurethane (25 to 200mm only)						--- Q ---	
C - Pipe Connection							
Wafer JIS10K						--- 11 ---	•
Wafer JIS20K						--- 12 ---	•
Wafer JIS30K						--- 13 ---	•
Wafer JIS10/20K for 10mm flange						--- 14 ---	g
Wafer JIS30K for 10mm flange						--- 15 ---	g
Wafer ANSI150						--- 21 ---	• * h
Wafer ANSI300						--- 22 ---	•
Wafer JIS G3451 F12 (diameter 80mm or larger)						--- 31 ---	•
Wafer DIN PN10						--- 41 ---	•
Wafer DIN PN16						--- 42 ---	•
Wafer DIN PN25						--- 43 ---	•
Wafer DIN PN40						--- 44 ---	•
Wafer DIN PN10/16/25/40 for 10mm flange						--- 45 ---	g
Wafer JPI150						--- 61 ---	•
Wafer JPI300						--- 62 ---	•

Table I continued on next page.

Availability

MGG17D
Selection

TABLE I (Continued)

		MGG17D Selection	Availability	
D - Electrodes				
SUS316L		----- L -----	•	*
Hastelloy C	(with Teflon PFA only)	----- C -----	c	
Titanium		----- K -----	•	
Zirconium	(with Teflon PFA only)	----- H -----	c	
Tantalum	(with Teflon PFA only)	----- T -----	c	
Tungsten Carbide	(only for size 10mm and above)	----- W -----	e	
Platinum-Iridium	(with Teflon PFA only)	----- P -----	c	
Alloy 20	(with Teflon PFA only)	----- A -----	c	
Hastelloy B	(with Teflon PFA only)	----- B -----	c	
SUS304	(with Teflon PFA only)	----- E -----	c	
Monel	(with Teflon PFA only)	----- M -----	c	
Nickel	(with Teflon PFA only)	----- N -----	f	
SUS316L Protruded Tip	(with Teflon PFA 15-200mm only)	----- 1 -----	f	
SUS316L for Alumina with Flat Tip	(with Teflon PFA 15-200mm only)	----- 2 -----	f	
SUS316L for Alumina with Pointed Tip	(with Teflon PFA 15-200mm only)	----- 3 -----	f	
E - Grounding Rings				
SUS316		----- S -----	•	*
SS Top Hat Style (Upstream Only)		----- G -----	c	
Hastelloy C	(with Teflon PFA only)	----- C -----	c	
Titanium		----- K -----	•	
Zirconium	(with Teflon PFA only)	----- H -----	c	
Tantalum	(with Teflon PFA only)	----- T -----	c	
Platinum	(with Teflon PFA only)	----- P -----	c	
Alloy 20	(with Teflon PFA only)	----- A -----	c	
Hastelloy B	(with Teflon PFA only)	----- B -----	c	
SUS304	(with Teflon PFA only)	----- E -----	c	
SUS316L	(with Teflon PFA only)	----- L -----	c	
Nickel	(with Teflon PFA only)	----- N -----	c	
F - Wiring Connection				
1/2" NPT Internal Thread without Watertight Gland		----- 5 -----	•	*
G - Face to Face Dimension				
Standard		----- A -----	•	*
Competitive (Refer to Table 103 and Consult Factory)		----- 9 -----	•	
H - Installation/Wiring Direction - Remote Only				
Upstream Side (horizontal/vertical piping mounting)		----- A -----	•	*
Downstream Side (horizontal/vertical piping mounting)		----- B -----	•	
Horizontal Piping Mounting/Left Side Viewed from Upstream		----- C -----	•	
Horizontal Piping Mounting/Right Side Viewed from Upstream		----- D -----	•	
I - Calibration				
Standard Calibration - 2 Point (0, 100%) w/ Master Converter		----- R -----	•	*
3 Point (0, 50, 100%) with Master Converter		----- P -----	•	
5 Point (0, 25, 50, 75, 100%) with Master Converter		----- Q -----	•	
2 Point (0, 100%) with Customer's Specific Converter		----- J -----	•	
3 Point (0, 50, 100%) with Customer's Specific Converter		----- A -----	•	
5 Point (0, 25, 50, 75, 100%) with Customer's Specific Converter		----- E -----	•	

		MGG17D Selection	Availability
TABLE II			
A - Finish			
Standard		X _	• *
Corrosion-resistant Finish		1 _	•
Corrosion-proof Finish		2 _	•
B - Bolts/Nuts			
None		_ X	• *
Carbon Steel		_ 1	•
SUS304		_ 2	•

TABLE III			
Version			
Standard		S	• *

TABLE IV			
Options			
Calibration Certificate (additional copy)		A	•
Traceability Certificate		B	•
Mill Sheet (only for electrodes and grounding rings)		C	•
Gasket for Plastic Piping		J	•
Attachment of Tagplate to Detector Terminal Box (Note 1)		K	•
Attachment of Tagplate to Neck of Detector (Note 1)		L	•
Specific Color Finish (Note 2)		P	•

Note 1: Must be selected if Tag number is required.

Note 2: Order must specify Munsell color number.

RESTRICTIONS

Restrictions Letter						Available Only With		Not Available With	
c	d	e	f	g	h	Table	Selection	Table	Selection
■						IB	___ P		
	■							IA	002, 005, 010, 015
		■						IA	002, 005
			■			IB	___ P	IA	002, 005, 010
				■		IA	010		
					■	IA	080, 100, 125, 150, 200		

MGG17F

TABLE I (Continued)

		Selection	Availability
Flange ANSI 150 (diameter 80mm or larger)	SUS304	--- A14 ---	e
Flange ANSI 300 (diameter 80mm or larger)	SUS304	--- A24 ---	e
Flange JIS G3451 F12 (diameter 80mm or larger)	SUS304	--- G14 ---	e
Flange DIN PN10 (diameter 80mm or larger)	SUS304	--- D14 ---	e
Flange DIN PN16 (diameter 80mm or larger)	SUS304	--- D24 ---	e
Flange DIN PN25 (diameter 80mm or larger)	SUS304	--- D34 ---	e
Flange DIN PN40 (diameter 80mm-200mm)	SUS304	--- D44 ---	k
Flange JPI150 (diameter 80mm-200mm)	SUS304	--- P14 ---	k
Flange JPI300 (diameter 80mm-200mm)	SUS304	--- P24 ---	k
D - Electrodes			
SUS316L		--- L ---	• *
Hastelloy C	(with Teflon PFA only)	--- C ---	c
Titanium		--- K ---	•
Zirconium	(with Teflon PFA only)	--- H ---	c
Tantalum	(with Teflon PFA only)	--- T ---	c
Tungsten Carbide		--- W ---	•
Platinum-Iridium	(with Teflon PFA only)	--- P ---	c
Alloy 20	(with Teflon PFA only)	--- A ---	c
Hastelloy B	(with Teflon PFA only)	--- B ---	c
SUS304	(with Teflon PFA only)	--- E ---	c
Monel	(with Teflon PFA only)	--- M ---	c
Nickel	(with Teflon PFA 25-200mm only)	--- N ---	g
SUS316L Protruded Tip	(with Teflon PFA 25-200mm only)	--- 1 ---	g
SUS316L for Alumina with Flat Tip	(with Teflon PFA 25-200mm only)	--- 2 ---	g
SUS316L for Alumina with Pointed Tip	(with Teflon PFA 25-200mm only)	--- 3 ---	g
E - Grounding Rings			
SUS316		--- S ---	• *
SS Top Hat Style (Upstream Only)		--- G ---	c
Hastelloy C	(with Teflon PFA only)	--- C ---	c
Titanium		--- K ---	•
Zirconium	(with Teflon PFA 25-200mm only)	--- H ---	g
Tantalum	(with Teflon PFA 25-200mm only)	--- T ---	g
Platinum	(with Teflon PFA 25-200mm only)	--- P ---	g
Alloy 20	(with Teflon PFA only)	--- A ---	c
Hastelloy B	(with Teflon PFA only)	--- B ---	c
SUS304	(with Teflon PFA only)	--- E ---	c
SUS316L	(with Teflon PFA only)	--- L ---	c
Nickel	(with Teflon PFA only)	--- N ---	c
F - Wiring Connection/Water Tight Gland			
NPT1/2 Internal Thread without Water Tight Gland		--- 5 ---	• *
G - Face to Face Dimension			
Standard		--- A ---	• *
Competitive (Refer to Table 103 and Consult Factory)		--- 9 ---	•
H - Installation/Wiring Direction - Remote Only			
Upstream Side (horizontal/vertical piping mounting)		--- A ---	• *
Downstream Side (horizontal/vertical piping mounting)		--- B ---	•
Horizontal Piping Mounting/Left Side Viewed from Upstream		--- C ---	•
Horizontal Piping Mounting/Right Side Viewed from Upstream		--- D ---	•
I - Calibration			
Standard Calibration - 2 Point (0, 100%) w/ Master Converter		--- R ---	• *
3 Point (0, 50, 100%) with Master Converter		--- P ---	•
5 Point (0, 25, 50, 75, 100%) with Master Converter		--- Q ---	•
2 Point (0, 100%) with Customer's Specific Converter		--- J ---	•
3 Point (0, 50, 100%) with Customer's Specific Converter		--- A ---	•
5 Point (0, 25, 50, 75, 100%) with Customer's Specific Converter		--- E ---	•

Availability

MGG17F

Selection



TABLE II

A - Finish	Selection	Availability
Standard	X	•
Corrosion-resistant Finish	1	•
Corrosion-proof Finish	2	•

*

TABLE III

Version	Selection	Availability
Standard	S	•

*

TABLE IV

Options	Selection	Availability
Calibration Certificate (additional copy)	A	•
Traceability Certificate	B	•
Mill Sheet (only for electrodes and grounding rings)	C	•
Gasket for Plastic Piping	J	•
Attachment of Tagplate to Detector Terminal Box (Note 1)	K	•
Attachment of Tagplate to Neck of Detector (Note 1)	L	•
Specific Color Finish (Note 2)	P	•

Note 1: Must be selected if Tag number is required.

Note 2: Order must specify Munsell color number.

RESTRICTIONS

Restrictions Letter	Available Only With		Not Available With	
	Table	Selection	Table	Selection
c	IB	--- P		
d	IA	025 to 200		
e			IA	250 to 400mm
f			IA	015 to 65mm
g				
h				
k	IA	080 to 200		

MagneW 3000 *PLUS* Remote Detector Wafer Type, Size 2.5-200mm

Model Selection Guide

Instructions

- Select the desired key number. The arrow to the right marks the selection available.
 - Make one selection from Tables I thru III, using the column below the proper arrow. Select as many Table IV options as desired. (If no selections are desired, specify 00.) A dot (•) denotes unrestricted availability. A letter denotes restricted availability. Restrictions follow Table IV.
 - A complete Model Number must have the designated number of digits in each table.
- Key Number I II III IV
- -
 -
 -

* = Stocked

KEY NUMBER	Selection	Availability
Description		
MagneW 3000 <i>PLUS</i> Remote Detector, Wafer Type, Sizes 2.5-200mm	MGG18D	↓

TABLE I

A - Diameter		Flow Range Minimum		Flow Range Maximum				
Millimeter	Inches	In US GPM	In Litres	In US GPM	In Litres			
2.5	0.1	0.008	0.03	0.779	2.95	002	•	
5.0	0.2	0.031	0.12	3.113	11.78	005	•	
10	0.39	0.125	0.47	12.460	47.17	010	•	
15	0.5	0.280	1.06	28.002	106.00	015	•	
25	1.0	0.779	2.95	77.931	295.00	025	•	
40	1.5	1.990	7.53	199.011	753.34	040	•	
50	2.0	3.113	11.78	311.285	1178.34	050	•	
65	2.5	5.239	19.83	523.945	1983.34	065	•	
80	3.0	7.969	30.17	796.924	3016.68	080	•	
100	4.0	12.46	47.17	1246.02	4716.68	100	•	
125	5.0	19.46	73.67	1946.08	7366.69	125	•	
150	6.0	28.00	106.00	2800.24	10600.04	150	•	
200	8.0	49.80	188.50	4979.68	18850.07	200	•	
B - Liner								
Ceramic							_ _ _ C _ _ _	j
PFA							_ _ _ P _ _ _	• *
Polyurethane Rubber (25 to 200mm only)							_ _ _ Q _ _ _	d
C - Pipe Connection								
Wafer JIS10K							_ _ _ 11 _ _ _	•
Wafer JIS20K							_ _ _ 12 _ _ _	•
Wafer JIS30K							_ _ _ 13 _ _ _	•
Wafer JIS10/20K for 10mm flange							_ _ _ 14 _ _ _	g
Wafer JIS30K for 10mm flange							_ _ _ 15 _ _ _	g *
Wafer ANSI150							_ _ _ 21 _ _ _	• *
Wafer ANSI300							_ _ _ 22 _ _ _	•
Wafer JIS G3451 F12 (diameter 80mm or larger)							_ _ _ 31 _ _ _	h
Wafer DIN PN10							_ _ _ 41 _ _ _	•
Wafer DIN PN16							_ _ _ 42 _ _ _	•
Wafer DIN PN25							_ _ _ 43 _ _ _	•
Wafer DIN PN40							_ _ _ 44 _ _ _	•
Wafer DIN PN10/16/25/40 for 10mm flange							_ _ _ 45 _ _ _	g
Wafer JPI150							_ _ _ 61 _ _ _	•
Wafer JPI300							_ _ _ 62 _ _ _	•

Table I continued on next page.

Availability

MGG18D
Selection

TABLE I (continued)

		MGG18D Selection	Availability
D - Electrodes			
SUS316L		----- L -----	• *
Hastelloy C	(with Teflon PFA only)	----- C -----	n
Titanium		----- K -----	•
Zirconium	(with Teflon PFA only)	----- H -----	n
Tantalum	(with Teflon PFA only)	----- T -----	n
Tungsten Carbide	(only for size 10mm and above)	----- W -----	e
Platinum-Iridium	(with Teflon PFA only)	----- P -----	n
Alloy 20	(with Teflon PFA only)	----- A -----	c
Hastelloy B	(with Teflon PFA only)	----- B -----	n
SUS304	(with Teflon PFA only)	----- E -----	c
Monel	(with Teflon PFA only)	----- M -----	c
Nickel	(with Teflon PFA 15-200mm only)	----- N -----	f
SUS316L Protruded Tip	(with Teflon PFA 15-200mm only)	----- 1 -----	f
SUS316L for Alumina with Flat Tip	(with Teflon PFA 15-200mm only)	----- 2 -----	f
SUS316L for Alumina with Pointed Tip	(with Teflon PFA 15-200mm only)	----- 3 -----	f
E - Grounding Rings			
SUS316		----- S -----	• *
SS Top Hat Style (Upstream Only)		----- G -----	c
Hastelloy C	(with Teflon PFA only)	----- C -----	c
Titanium		----- K -----	•
Zirconium	(with Teflon PFA only)	----- H -----	c
Tantalum	(with Teflon PFA only)	----- T -----	c
Platinum	(Note 3)	----- P -----	n
Alloy 20	(with Teflon PFA only)	----- A -----	c
Hastelloy B	(with Teflon PFA only)	----- B -----	c
SUS304	(with Teflon PFA only)	----- E -----	c
SUS316L	(with Teflon PFA only)	----- L -----	c
Nickel	(with Teflon PFA only)	----- N -----	c
F - Wiring Connection/Water Tight Gland			
G1/2 Internal Thread without Water Tight Gland (Not CSA/FM approved)		----- 2 -----	•
G1/2 Internal Thread with Brass (Ni-plated) Water Tight Gland (Not CSA/FM approved)		----- 3 -----	•
G1/2 Internal Thread with Plastic Water Tight Gland (Not CSA/FM approved)		----- 4 -----	•
1/2 NPT Internal Thread without Water Tight Gland (CSA/FM NI approved)		----- 5 -----	• *
CM20 Internal Thread without Water Tight Gland (Not CSA/FM approved)		----- 6 -----	•
Pg13.5 Internal Thread without Water Tight Gland (Not CSA/FM approved)		----- 7 -----	•
G1/2 Internal Thread with SUS304 Water Tight Gland (Not CSA/FM approved)		----- 8 -----	•
G - Face to Face Dimension			
Standard		----- A -----	• *
Competitive (refer to Table 103 and consult factory)		----- 9 -----	c
H - Installation/Wiring Direction			
Upstream Side (horizontal/vertical piping mounting)		----- A -----	• *
Downstream Side (horizontal/vertical piping mounting)		----- B -----	•
Horizontal Piping Mounting/Left Side Viewed from Upstream		----- C -----	•
Horizontal Piping Mounting/Right Side Viewed from Upstream		----- D -----	•

Availability

MGG18D

Selection



TABLE I (continued)

I - Calibration	MGG18D Selection	Availability
Standard Calibration - 2 Point (0, 100%) w/ Master Converter	----- R	• *
3 Point (0, 50, 100%) with Master Converter	----- P	•
5 Point (0, 25, 50, 75, 100%) with Master Converter	----- Q	•
2 Point (0, 100%) with Customer's Specific Converter	----- J	•
3 Point (0, 50, 100%) with Customer's Specific Converter	----- A	•
5 Point (0, 25, 50, 75, 100%) with Customer's Specific Converter	----- E	•

TABLE II

A - Finish	MGG18D Selection	Availability
Standard	X _	• *
Corrosion-resistant Finish	1 _	•
Corrosion-proof Finish	2 _	•
B - Bolts/Nuts	MGG18D Selection	Availability
None	_ X	• *
Carbon Steel	_ 1	•
SUS304	_ 2	•

TABLE III

Version	MGG18D Selection	Availability
Standard	S	• *

TABLE IV

Options	MGG18D Selection	Availability
Calibration Certificate (additional copy)	A	•
Traceability Certificate	B	•
Mill Sheet (only for electrodes and grounding rings)	C	•
Gasket for Plastic Piping	J	•
Attachment of Tagplate to Detector Terminal Box (Note 1)	K	•
Attachment of Tagplate to Neck of Detector (Note 1)	L	•
Specific Color Finish (Note 2)	P	•

Note 1: Must be selected if Tag number is required.

Note 2: Order must specify Munsell color number.

Note 3: Ceramic Liner - Platinum Metalized Rings are supplied
PFA Liner - Platinum Iridium Rings are supplied

RESTRICTIONS

Restriction Letter	Available Only With		Not Available With	
	Table	Selection	Table	Selection
c	IB	___ P		
d			IA	002, 005, 010
e	IB	___ Q or ___ P	IA	002, 005
f	IB	___ P	IA	002, 005, 010
g	IA	002P, 005P, 010P		
h	IA	080, 100, 125, 150, 200		
j	IA	015, 025, 040, 050, 080, 100		
n	IB	___ C or ___ P		

TABLE I (Continued)

		Selection	Availability
Flange JIS 10K (diameter 80mm or larger)	SUS304	----- J14 -----	e
Flange JIS 20K (diameter 80mm or larger)	SUS304	----- J24 -----	e
Flange JIS 30K (diameter 80mm-200mm)	SUS304	----- J34 -----	m
Flange ANSI 150 (diameter 80mm or larger)	SUS304	----- A14 -----	e
Flange ANSI 300 (diameter 80mm-450mm only)	SUS304	----- A24 -----	n
Flange JIS G3451 F12 (diameter 80mm or larger)	SUS304	----- G14 -----	e
Flange DIN PN10 (diameter 80mm or larger)	SUS304	----- D14 -----	e
Flange DIN PN16 (diameter 80mm or larger)	SUS304	----- D24 -----	e
Flange DIN PN25 (diameter 80mm or larger)	SUS304	----- D34 -----	e
Flange DIN PN40 (diameter 80mm-200mm)	SUS304	----- D44 -----	m
Flange JPI150 (diameter 80mm-200mm)	SUS304	----- P14 -----	m
Flange JPI300 (diameter 80mm-200mm)	SUS304	----- P24 -----	m
D - Electrodes			
SUS316L		----- L -----	•
Hastelloy C (with Teflon PFA only)		----- C -----	c
Titanium		----- K -----	•
Zirconium (with Teflon PFA only)		----- H -----	c
Tantalum (with Teflon PFA only)		----- T -----	c
Tungsten Carbide		----- W -----	•
Platinum-Iridium (with Teflon PFA only)		----- P -----	c
Alloy 20 (with Teflon PFA only)		----- A -----	c
Hastelloy B (with Teflon PFA only)		----- B -----	c
SUS304 (with Teflon PFA only)		----- E -----	c
Monel (with Teflon PFA only)		----- M -----	c
Nickel (with Teflon PFA 15-200mm only)		----- N -----	g
SUS316L Protruded Tip (with Teflon PFA 15-200mm only)		----- 1 -----	g
SUS316L for Alumina with Flat Tip (with Teflon PFA 15-200mm only)		----- 2 -----	g
SUS316L for Alumina with Pointed Tip (with Teflon PFA 15-200mm only)		----- 3 -----	g
E - Grounding Rings			
SUS316		----- S -----	•
SS Top Hat Style (Upstream Only)		----- G -----	c
Hastelloy C (with Teflon PFA only)		----- C -----	c
Titanium		----- K -----	•
Zirconium (with Teflon PFA 15-200mm only)		----- H -----	g
Tantalum (with Teflon PFA 15-200mm only)		----- T -----	g
Platinum (with Teflon PFA 15-200mm only)		----- P -----	g
Alloy 20 (with Teflon PFA only)		----- A -----	c
Hastelloy B (with Teflon PFA only)		----- B -----	c
SUS304 (with Teflon PFA only)		----- E -----	c
SUS316L (with Teflon PFA only)		----- L -----	c
Nickel (with Teflon PFA only)		----- N -----	c
F - Wiring Connection/Water Tight Gland			
G1/2 Internal Thread without Water Tight Gland (Not CSA/FM approved)		----- 2 -----	•
G1/2 Internal Thread with Brass (Ni-plated) Water Tight Gland (Not CSA/FM approved)		----- 3 -----	•
G1/2 Internal Thread with Plastic Water Tight Gland (Not CSA/FM approved)		----- 4 -----	•
1/2 NPT Internal Thread without Water Tight Gland (CSA/FM NI approval)		----- 5 -----	•
CM20 Internal Thread without Water Tight Gland (Not CSA/FM approved)		----- 6 -----	•
Pg13.5 Internal Thread without Water Tight Gland (Not CSA/FM approved)		----- 7 -----	•
G1/2 Internal Thread with SUS304 Water Tight Gland (Not CSA/FM approved)		----- 8 -----	•

*

*

*

Availability

MGG18F

Selection

G - Face to Face Dimension			
Standard		----- A --	• *
Competitive (refer to Table 103 and consult factory)		----- 9 --	c
H - Installation/Wiring Direction - Remote Only			
Upstream Side (horizontal/vertical piping mounting)		----- A --	• *
Downstream Side (horizontal/vertical piping mounting)		----- B --	•
Horizontal Piping Mounting/Left Side Viewed from Upstream		----- C --	•
Horizontal Piping Mounting/Right Side Viewed from Upstream		----- D --	•
I - Calibration			
Standard Calibration - 2 Point (0, 100%) w/ Master Converter		----- R --	• *
3 Point (0, 50, 100%) with Master Converter		----- P --	•
5 Point (0, 25, 50, 75, 100%) with Master Converter		----- Q --	•
2 Point (0, 100%) with Customer's Specific Converter		----- J --	•
3 Point (0, 50, 100%) with Customer's Specific Converter		----- A --	•
5 Point (0, 25, 50, 75, 100%) with Customer's Specific Converter		----- E --	•

TABLE II

A - Finish			
Standard		X	• *
Corrosion-resistant Finish		1	•
Corrosion-proof Finish		2	•

TABLE III

Version			
Standard		S	• *

TABLE IV

Options			
Calibration Certificate (additional copy)		A	•
Traceability Certificate		B	•
Mill Sheet (only for electrodes and grounding rings)		C	•
Gasket for Plastic Piping		J	•
Attachment of Tagplate to Detector Terminal Box (Note 1)		K	•
Attachment of Tagplate to Neck of Detector (Note 1)		L	•
Specific Color Finish (Note 2)		P	•

Note 1: Must be selected if Tag number is required.

Note 2: Order must specify Munsell color number.

RESTRICTIONS

Restrictions Letter	Available Only With		Not Available With	
	Table	Selection	Table	Selection
■ c	IB	--- P		
■ d	IA	025 to 200		
■ e	IB	--- P	IA	025 to 65mm
■ f			IA	250 to 600mm
■ g	IB	--- P	IA	250 to 600mm
■ h			IA	025 to 65mm
■ j			IA	500, 600mm
■ m	IA	080 to 200mm		
■ n	1B	--- P		
	1A	080 to 450mm		
	IB	--- P		

MagneW 3000 *PLUS* Submersible Detector Model Selection Guide

Remote Detector, 'Wafer Type, Size 15-200mm (with Integral Cable)

Instructions

- Select the desired key number. The arrow to the right marks the selection available.
- Make one selection from Tables I thru III, using the column below the proper arrow. Select as many Table IV options as desired. (If no selections are desired, specify 00.) A dot (•) denotes unrestricted availability. A letter denotes restricted availability. Restrictions follow Table IV.
- A complete Model Number must have the designated number of digits in each table.

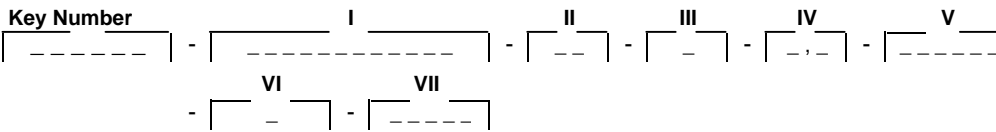

KEY NUMBER	Selection	Availability
Description		
MagneW 3000 <i>PLUS</i> Submersible Detector, Wafer Type, Sizes 15-200mm	MGG19D	↓

TABLE I

A - Diameter		Flow Range Minimum		Flow Range Maximum			
Millimeter	Inches	In US GPM	In Litres	In US GPM	In Litres		
15	0.5	0.280	1.06	28.002	106.00	015 _____	•
25	1.0	0.779	2.95	77.931	295.00	025 _____	•
40	1.5	1.990	7.53	199.011	753.34	040 _____	•
50	2.0	3.113	11.78	311.285	1178.34	050 _____	•
65	2.5	5.239	19.83	523.945	1983.34	065 _____	•
80	3.0	7.969	30.17	796.924	3016.68	080 _____	•
100	4.0	12.46	47.17	1246.02	4716.68	100 _____	•
125	5.0	19.46	73.67	1946.08	7366.69	125 _____	•
150	6.0	28.00	106.00	2800.24	10600.04	150 _____	•
200	8.0	49.80	188.50	4979.68	18850.07	200 _____	•
B - Liner							
PFA						___ P _____	•
Polyurethane Rubber (25 to 200mm only)						___ Q _____	d
C - Pipe Connection							
Wafer JIS10K						___ 11 _____	•
Wafer JIS20K						___ 12 _____	•
Wafer JIS30K						___ 13 _____	•
Wafer ANSI150						___ 21 _____	•
Wafer ANSI300						___ 22 _____	•
Wafer JIS G3451 F12 (diameter 80mm or larger)						___ 31 _____	h
Wafer DIN PN10						___ 41 _____	•
Wafer DIN PN16						___ 42 _____	•
Wafer DIN PN25						___ 43 _____	•
Wafer DIN PN40						___ 44 _____	•
Wafer JPI150						___ 61 _____	•
Wafer JPI300						___ 62 _____	•

Table I continued on next page.

Availability

MGG19D

TABLE I (continued)

		Selection	Availability
D - Electrodes			
SUS316L		----- L -----	•
Hastelloy C	(with Teflon PFA only)	----- C -----	c
Titanium		----- K -----	•
Zirconium	(with Teflon PFA only)	----- H -----	c
Tantalum	(with Teflon PFA only)	----- T -----	c
Tungsten Carbide		----- W -----	•
Platinum-Iridium	(with Teflon PFA only)	----- P -----	c
Alloy 20	(with Teflon PFA only)	----- A -----	c
Hastelloy B	(with Teflon PFA only)	----- B -----	c
SUS304	(with Teflon PFA only)	----- E -----	c
Monel	(with Teflon PFA only)	----- M -----	c
Nickel	(with Teflon PFA only)	----- N -----	c
SUS316L Protruded Tip	(with Teflon PFA only)	----- 1 -----	c
SUS316L for Alumina with Flat Tip	(with Teflon PFA only)	----- 2 -----	c
SUS316L for Alumina with Pointed Tip	(with Teflon PFA only)	----- 3 -----	c
E - Grounding Rings			
SUS316		----- S -----	•
SS Top Hat Style (Upstream Only)		----- G -----	c
Hastelloy C	(with Teflon PFA only)	----- C -----	c
Titanium		----- K -----	•
Zirconium	(with Teflon PFA only)	----- H -----	c
Tantalum	(with Teflon PFA only)	----- T -----	c
Platinum	(with Teflon PFA only)	----- P -----	c
Alloy 20	(with Teflon PFA only)	----- A -----	c
Hastelloy B	(with Teflon PFA only)	----- B -----	c
SUS304	(with Teflon PFA only)	----- E -----	c
SUS316L	(with Teflon PFA only)	----- L -----	c
Nickel	(with Teflon PFA only)	----- N -----	c
F - Wiring Connection/Water Tight Gland			
G1/2 Internal Thread with Brass (Ni-plated) Water Tight Gland		----- 3 -----	•
G1/2 Internal Thread with SUS304 Water Tight Gland		----- 8 -----	•
G - Face to Face Dimension			
Standard		----- A -----	•
Competitive Refer to Table 103 and Consult Factory)		----- 9 -----	c
H - Installation/Wiring Direction - Remote Only			
Upstream Side (horizontal/vertical piping mounting)		----- A -----	•
Downstream Side (horizontal/vertical piping mounting)		----- B -----	•
Horizontal Piping Mounting/Left Side Viewed from Upstream		----- C -----	•
Horizontal Piping Mounting/Right Side Viewed from Upstream		----- D -----	•
I - Calibration			
Standard Calibration - 2 Point (0, 100%) w/ Master Converter		----- R -----	•
3 Point (0, 50, 100%) with Master Converter		----- P -----	•
5 Point (0, 25, 50, 75, 100%) with Master Converter		----- Q -----	•
2 Point (0, 100%) with Customer's Specific Converter		----- J -----	•
3 Point (0, 50, 100%) with Customer's Specific Converter		----- A -----	•
5 Point (0, 25, 50, 75, 100%) with Customer's Specific Converter		----- E -----	•

Availability

MGG19D

Selection



TABLE II

A - Finish		
Standard	X _	•
B - Bolts/Nuts		
None	_ X	•
Carbon Steel	_ 1	•
SUS304	_ 2	•

TABLE III

Version		
Standard	S	•

TABLE IV

Options		
None	X	•
Calibration Certificate (additional copy)	A	•
Traceability Certificate	B	•
Mill Sheet (only for electrodes and grounding rings)	C	•
Gasket for Plastic Piping	J	•
Attachment of Tagplate to Detector Terminal Box (Note 1)	K	•
Attachment of Tagplate to Neck of Detector (Note 1)	L	•
Specific Color Finish (Note 2)	P	•

TABLE V

Integral Cable		
MagneW PLUS Cables	MGA12W	•

TABLE VI

Cable Item		
Signal Cable and Excitation Cable	C	•

TABLE VII

A - Length				
	Meters	Feet		
	2	6	002 _ _	•
	3	9	003 _ _	•
	4	12	004 _ _	•
	5	15	005 _ _	•
	6	18	006 _ _	•
	10	30	010 _ _	•
	15	45	015 _ _	•
	20	60	020 _ _	•
	30	90	030 _ _	•
	40	120	040 _ _	•
	50	150	050 _ _	•
	60	180	060 _ _	•
	70	210	070 _ _	•
	80	240	080 _ _	•
	90	270	090 _ _	•
	100	300	100 _ _	•
	150	450	150 _ _	•
	200	600	200 _ _	•
	250	750	250 _ _	•
	300	1000	300 _ _	•
	Other length (longer than 10m, 300m Max)		XXX _ _	•

Table VII continued on next page.

TABLE VII (continued)		MGG19D Selection	Availability ↓
B - Terminals (Detector Side)			
With Terminals for MGG Type Detector (MG <i>PLUS</i>)		_ _ _ A _	•
C - Terminals (Converter Side)			
Without Terminals		_ _ _ _ X	•
With Terminals for MGG/KIX/KIC Type Converter		_ _ _ _ A	•

Note 1: Must be selected if Tag number is required.

Note 2: Order must specify Munsell color number.

RESTRICTIONS

Restrictions Letter	Available Only With		Not Available With	
	Table	Selection	Table	Selection
c	IB	_ _ _ P		
d			IA	015
h	IA	080, 100, 125, 150, 200		

MagneW 3000 *PLUS* Submersible Remote Detector, Flange Type, Size 25-600mm (with Integral Cable)

Model Selection Guide

Instructions

- Select the desired key number. The arrow to the right marks the selection available.
- Make one selection from Tables I thru III, using the column below the proper arrow. Select as many Table IV options as desired. (If no selections are desired, specify 00.) A dot (•) denotes unrestricted availability. A letter denotes restricted availability. Restrictions follow Table IV.
- A complete Model Number must have the designated number of digits in each table.

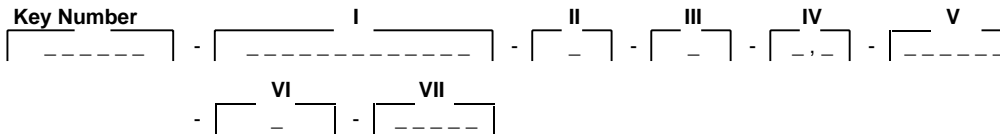

KEY NUMBER	Selection	Availability
Description		
MagneW 3000 <i>PLUS</i> Submersible Remote Detector, Flange Type, Sizes 25-600mm	MGG19F	↓

TABLE I

A - Diameter		Flow Range Minimum		Flow Range Maximum					
Millimeter	Inches	In US GPM	In Litres	In US GPM	In Litres				
25	1.0	0.779	2.95	77.931	295.00	025	•		
40	1.5	1.990	7.53	199.011	753.34	040	•		
50	2.0	3.113	11.78	311.285	1178.34	050	•		
65	2.5	5.239	19.83	523.945	1983.34	065	•		
80	3.0	7.969	30.17	796.924	3016.68	080	•		
100	4.0	12.46	47.17	1246.02	4716.68	100	•		
125	5.0	19.46	73.67	1946.08	7366.69	125	•		
150	6.0	28.00	106.00	2800.24	10600.04	150	•		
200	8.0	49.80	188.50	4979.68	18850.07	200	•		
250	9.8	77.80	294.50	7779.92	29450.11	250	•		
300	11.8	112.05	424.17	11205.37	42416.82	300	•		
350	13.8	152.52	577.34	15251.64	57733.55	350	•		
400	15.8	199.19	754.00	19918.71	75400.28	400	•		
450	17.7	252.11	954.34	25210.99	95433.69	450	•		
500	19.7	311.28	1178.34	31128.49	117833.77	500	•		
600	23.6	448.17	1696.51	44817.09	169650.63	600	•		
B - Liner									
PFA						P	•		
Polyurethane Rubber (25 to 200mm only)						Q	d		
C - Pipe Connection				Flange Material					
Flange JIS10K				Standard				J11	•
Flange JIS20K				Standard				J21	•
Flange JIS30K (diameter 25mm-200mm only)				Standard				J31	f
Flange ANSI 150				Standard				A11	•
Flange ANSI 300 (diameter 25mm-450mm only)				Standard				A21	m
Flange JIS G3451 F12 (diameter 80mm or larger)				Standard				G11	h
Flange DIN PN10				Standard				D11	•
Flange DIN PN16				Standard				D21	•
Flange DIN PN25				Standard				D31	•
Flange DIN PN40 (diameter 25mm-200mm only)				Standard				D41	f

Table I continued on next page.

Availability

MGG19F

TABLE I (Continued)

Selection



Flange JPI 150	Standard	----- P11 -----	•
Flange JPI 300	Standard	----- P21 -----	m
Flange JIS 10K (diameter 80mm or larger)	SUS304	----- J14 -----	e
Flange JIS 20K (diameter 80mm or larger)	SUS304	----- J24 -----	e
Flange JIS 30K (diameter 80mm-200mm only)	SUS304	----- J34 -----	k
Flange ANSI 150 (diameter 80mm or larger)	SUS304	----- A14 -----	e
Flange ANSI 300 (diameter 80mm-450mm only)	SUS304	----- A24 -----	j
Flange JIS G3451 F12 (diameter 80mm or larger)	SUS304	----- G14 -----	e
Flange DIN PN10 (diameter 80mm or larger)	SUS304	----- D14 -----	e
Flange DIN PN16 (diameter 80mm or larger)	SUS304	----- D24 -----	e
Flange DIN PN25 (diameter 80mm or larger)	SUS304	----- D34 -----	e
Flange DIN PN40 (diameter 80mm-200mm only)	SUS304	----- D44 -----	k
Flange JPI150 (diameter 80mm-200mm)	SUS304	----- P14 -----	k
Flange JPI300 (diameter 80mm-200mm)	SUS304	----- P24 -----	k
D - Electrodes			
SUS316L		----- L -----	•
SS Top Hat Style (Upstream Only)		----- G -----	c
Hastelloy C (with Teflon PFA only)		----- C -----	c
Titanium		----- K -----	•
Zirconium (with Teflon PFA only)		----- H -----	c
Tantalum (with Teflon PFA only)		----- T -----	c
Tungsten Carbide		----- W -----	•
Platinum-Iridium (with Teflon PFA only)		----- P -----	c
Alloy 20 (with Teflon PFA only)		----- A -----	c
Hastelloy B (with Teflon PFA only)		----- B -----	c
SUS304 (with Teflon PFA only)		----- E -----	c
Monel (with Teflon PFA only)		----- M -----	c
Nickel (with Teflon PFA 25-200mm only)		----- N -----	g
SUS316L Protruded Tip (with Teflon PFA 25-200mm only)		----- 1 -----	g
SUS316L for Alumina with Flat Tip (with Teflon PFA 25-200mm only)		----- 2 -----	g
SUS316L for Alumina with Pointed Tip (with Teflon PFA 25-200mm only)		----- 3 -----	g
E - Grounding Rings			
SUS316		----- S -----	•
Hastelloy C (with Teflon PFA only)		----- C -----	c
Titanium		----- K -----	•
Zirconium (with Teflon PFA 25-200mm only)		----- H -----	g
Tantalum (with Teflon PFA 25-200mm only)		----- T -----	g
Platinum (with Teflon PFA 25-200mm only)		----- P -----	g
Alloy 20 (with Teflon PFA only)		----- A -----	c
Hastelloy B (with Teflon PFA only)		----- B -----	c
SUS304 (with Teflon PFA only)		----- E -----	c
SUS316L (with Teflon PFA only)		----- L -----	c
Nickel (with Teflon PFA only)		----- N -----	c
SS Top Hat Style (Upstream Only)		----- G -----	c
F - Wiring Connection/Water Tight Gland			
G1/2 Internal Thread with Brass (Ni-plated) Water Tight Gland		----- 3 -----	•
G1/2 Internal Thread with SUS304 Water Tight Gland		----- 8 -----	•

Availability

MGG19F
Selection

G - Face to Face Dimension		
Standard	----- A -----	•
Competitive (Refer to Table 103 and Consult Factory)	----- 9 -----	c
H - Installation/Wiring Direction		
Upstream Side (horizontal/vertical piping mounting)	----- A -----	•
Downstream Side (horizontal/vertical piping mounting)	----- B -----	•
Horizontal Piping Mounting/Left Side Viewed from Upstream	----- C -----	•
Horizontal Piping Mounting/Right Side Viewed from Upstream	----- D -----	•
I - Calibration		
Standard Calibration - 2 Point (0, 100%) w/ Master Converter	----- R -----	•
3 Point (0, 50, 100%) with Master Converter	----- P -----	•
5 Point (0, 25, 50, 75, 100%) with Master Converter	----- Q -----	•
2 Point (0, 100%) with Customer's Specific Converter	----- J -----	•
3 Point (0, 50, 100%) with Customer's Specific Converter	----- A -----	•
5 Point (0, 25, 50, 75, 100%) with Customer's Specific Converter	----- E -----	•

TABLE II

A - Finish		
Standard	X	•

TABLE III

Version		
Standard	S	•

TABLE IV

Options		
None	X	•
Calibration Certificate (additional copy)	A	•
Traceability Certificate	B	•
Mill Sheet (only for electrodes and grounding rings)	C	•
Gasket for Plastic Piping	J	•
Attachment of Tagplate to Detector Terminal Box (Note 1)	K	•
Attachment of Tagplate to Neck of Detector (Note 1)	L	•
Specific Color Finish (Note 2)	P	•

TABLE V

Integral Cable		
MagneW PLUS Cables	MGA12W	•

TABLE VI

A - Cable Item		
Signal Cable and Excitation Cable	C	•

A - Length		Meters	Feet	MGG19F Selection	Availability
		2	6	002 __	•
		3	9	003 __	•
		4	12	004 __	•
		5	15	005 __	•
		6	18	006 __	•
		10	30	010 __	•
		15	45	015 __	•
		20	60	020 __	•
		30	90	030 __	•
		40	120	040 __	•
		50	150	050 __	•
		60	180	060 __	•
		70	210	070 __	•
		80	240	080 __	•
		90	270	090 __	•
		100	300	100 __	•
		150	450	150 __	•
		200	600	200 __	•
		250	750	250 __	•
		300	1000	300 __	•
		Other length (longer than 10m, 300m Max)		XXX __	•

TABLE VII (continued)

	Selection	Availability
B - Terminals (Detector Side)		
With Terminals for MGG Type Detector (MG <i>PLUS</i>)	___ A _	•
C - Terminals (Converter Side)		
Without Terminals	___ X	•
With Terminals for MGG/KIX/KIC Type Converter	___ A	•

Note 1: Must be selected if Tag number is required.

Note 2: Order must specify Munsell color number.

RESTRICTIONS

Restrictions Letter	Available Only With		Not Available With	
	Table	Selection	Table	Selection
c	IB	___ P		
d	IA	025 to 200		
e	IB	___ P	IA	025 to 65mm
f			IA	250 to 600mm
g	IB	___ P	IA	250 to 600mm
h			IA	025 to 65mm
j	IB	___ P	IA	500, 600mm
k	IA 1B	080 to 200 ___ P		
m			IA	500, 600mm

MagneW 3000 *PLUS* Cables

Model Selection Guide

Instructions

- Select the desired key number. The arrow to the right marks the selection available.
- Make one selection from Tables I thru II, using the column below the proper arrow.
A dot (•) denotes unrestricted availability. A letter denotes restricted availability.
Restrictions follow Table IV.
- A complete Model Number must have the designated number of digits in each table.
- A complete Model Number must have the designated number of digits in each table.

Key Number I II
 [-----] - [-] - [-----]

KEY NUMBER	Selection	Availability
Description		
MagneW <i>PLUS</i> Cables	MGA12W	↓

TABLE I

A - Cable Item		
Signal Cable and Excitation Cable	C	•

TABLE II

A - Length				
	Meters	Feet		
	2	6	002 __	•
	3	9	003 __	•
	4	12	004 __	•
	5	15	005 __	•
	6	18	006 __	•
	10	30	010 __	•
	15	45	015 __	•
	20	60	020 __	•
	30	90	030 __	•
	40	120	040 __	•
	50	150	050 __	•
	60	180	060 __	•
	70	210	070 __	•
	80	240	080 __	•
	90	270	090 __	•
	100	300	100 __	•
	150	450	150 __	•
	200	600	200 __	•
	250	750	250 __	•
	300	1000	300 __	•
	Other length (longer than 10m, 300m Max)		XXX __	•

Availability

TABLE II (continued)

	MGA12W Selection	↓
B - Terminals (Detector Side)		
Without Terminals	_ _ _ X _	•
With Terminals for MGG Type Detector (MG PLUS)	_ _ _ A _	•
With Terminals for KID Type Detector	_ _ _ B _	•
With Terminals for NNM TType Detector	_ _ _ C _	•
C - Terminals (Converter Side)		
Without Terminals	_ _ _ _ X	•
With Terminals for MGG/KIX/KIC Type Converter	_ _ _ _ A	•

MagneW 3000 PLUS Smart Magnetic Flowmeter

Application Data Sheet

Date: _____	Site Location: _____
Customer: _____	Honeywell Sales Contact: _____

1. Detector Requirements (Must specify data in **bold** typeface to place an order)

- **Environment:** **General Purpose Nonhazardous Area** **Hazardous Area** **Sanitary**
 Submersible ↳ CIP Yes NO
- **Process Liquid** _____
- **Electrodes:** SS316L Hast C Zirconium Tantalum Platinum-Iridium Other _____
- **Liner:** PFA Polyurethane rubber Chloroprene Ceramic
- **Process Temperature in °C or °F:** **Minimum:** _____ **Normal:** _____ **Maximum:** _____
- **Process Pressure in psi or bar:** **Minimum:** _____ **Normal:** _____ **Maximum:** _____
- **Density in g/cm³** :³ _____
(If specific gravity value is given for density, be sure to give reference temperature as well.)
- **Viscosity in cST, cP, or mPas:** **Minimum:** _____ **Maximum:** _____
- **Flow Range in GPM:**
Minimum: _____ **Normal:** _____ **Maximum:** _____
- **Nominal Pipe Diameter in "in" or "mm":** _____ • **Process Pipe Material:** _____
- **Process Pipe Lined:** Yes — Material type: _____
 NO
- **Pulsating Flow:** Yes NO
- **Process Connections:** DINPN ANSI (ANSI B16.5) Sanitary
- **Style:**
 Flanged Wafer
Flange Rating _____

2. Transmitter

- Mode of Operation: Analog DE
 HART (Option) Foundation Fieldbus

- Mounting Configuration: Integral Remote

- Power Supply: _____

- Safety Approvals Required:

- Process Measurement Output(s):
 Standard

- Contact Outputs: One Input and One Output
 2 Inputs

- Local Indicator: Yes NO

- Corrosion - resistant Coating Required: Yes NO

- Watertight Glands Required: Yes NO

3. Other Application Details or Special Requirements

- Describe any other information that would be pertinent to MagneW 3000 PLUS model selection:

По вопросам продаж и поддержки обращайтесь:
Астана +7(7172)727-132, Волгоград (844)278-03-48, Воронеж (473)204-51-73, Екатеринбург (343)384-55-89,
Казань (843)206-01-48, Краснодар (861)203-40-90, Красноярск (391)204-63-61, Москва (495)268-04-70,
Нижний Новгород (831)429-08-12, Новосибирск (383)227-86-73, Ростов-на-Дону (863)308-18-15,
Самара (846)206-03-16, Санкт-Петербург (812)309-46-40, Саратов (845)249-38-78, Уфа (347)229-48-12
Единый адрес: hwn@nt-rt.ru
www.honeywell.nt-rt.ru
