

VersaFlow Mag 3000 Electromagnetic Flow Sensor Technical Datasheet

34-VF-03-23
August 27th, 2008

Specification

Sanitary and hygienic solution

The VersaFlow Mag 3000 is the electromagnetic flow sensor for the food and beverage industry. The 3000 sensor is manufactured in conformance to FDA requirements and has all requested (needed) approvals available. As an add on, a EHEDG approval is available and documents the hygienic design and the clean ability of the device.

Together with the converters TWM 9000 or TWM 1000, the meter can be used for mixing and dosing applications. It offers also a special measuring mode for pulsating flow. Even for products with low conductivity e. g. glucose or high concentrated fruit concentrate the VersaFlow Mag 3000 is the first choice.

Due to the fact that the industrial production of beer, water and milk increases rapidly, the produced volume gets larger and larger pipe sizes are needed. The VersaFlow Mag 3000 is the only hygienic electro magnetic flow meter with a pipe size of DN150 / 6" (where the hygienic standards list such a size).

Figure 1 – VersaFlow Electromagnetic Flow Sensor



Highlights

- Developed in cooperation with customers from the food industry
- Stainless steel design for hygienic and aseptic operation
- Unique gasket concept prevents gasket from expanding into measuring tube
- Suitable for all CIP and SIP processes
- All industry-specific connectors and lengths
- High form stability and vacuum resistance

Industries

- Food & Beverages
- Pharmaceuticals
- Cosmetics

Applications

- For aseptic and hygienic applications
- Mixing, dosing and filling
- For pulsating flow

По вопросам продаж и поддержки обращайтесь:

Астана +7(7172)727-132, Волгоград (844)278-03-48, Воронеж (473)204-51-73, Екатеринбург (343)384-55-89,
Казань (843)206-01-48, Краснодар (861)203-40-90, Красноярск (391)204-63-61, Москва (495)268-04-70,
Нижний Новгород (831)429-08-12, Новосибирск (383)227-86-73, Ростов-на-Дону (863)308-18-15,
Самара (846)206-03-16, Санкт-Петербург (812)309-46-40, Саратов (845)249-38-78, Уфа (347)229-48-12

Единый адрес: hwn@nt-rt.ru

www.honeywell.nt-rt.ru

Features and Benefits



Stainless Steel Mesh

The reinforced PFA liner makes sure that the VersaFlow Mag 3000 keep its form stable. Even at high temperatures and very low pressure or vacuum the liner does not collapse and keeps its size. This is one reason why the meter is extremely accurate.

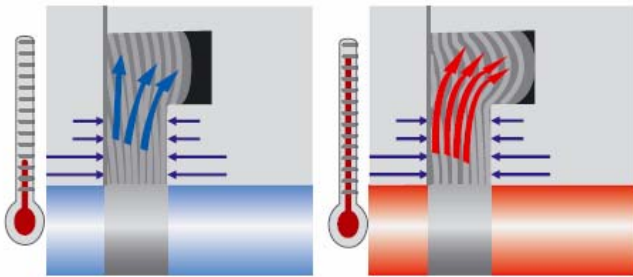

Unique Gasket Adapter Concept

With support of the TNO, a member of the European EHEDG organization, the sealing concept of the stainless steel adapters has been redesigned. A novel gasket concept prevents the gasket from expanding into the measuring tube. During the CIP/ SIP cleaning procedure, the gasket expands into the special constructed "expansion chamber" and not into the pipe section. This leads to a sharp sealing at the edge of the pipe line and a perfect transition into the measuring section. Additionally the gasket experiences less stress which results in a longer life time and reduced maintenance.

Stainless Steel converter housing



A regular cleaning procedure from outside, where aggressive cleaning agents are used, can attack the standard polyurethane coat of the converter. In these cases the cast stainless steel housing is recommended.

EHEDG and 3A approved

The VersaFlow Mag3000 is approved from EHEDG and 3A. The hygienic design of the meter and the cleanability of the equipment was tested. Such tests identify weak points in the hygienic design, including places where product residues may rest or where microbes may grow out during production time.

Technical Data

Nominal diameter													
[inch]	1/10"	1/8"	1/4"	3/8"	1/2"	1"	1 1/2"	2"	2 1/2"	3"	4"	5"	6"
[mm]	2.5	4	6	10	15	25	40	50	65	80	100	125	150

Measuring system

Versions													
Compact +TWM 9000 C													
Remote + TWM 9000 F, R, W													
Compact +TWM 1000 C													
Remote + TWM 1000 W													
Inlet	Min. 5DN												
Outlet	Min. 2DN												

Operating conditions

Ambient temperature	
Separate slow sensor	-40... +65 °C / -40... +150 °F
Compact version	-40... +65 °C / -40... +150 °F
Process temperature	
Separate slow sensor	-40... +180 °C / -40... +355 °F
Compact version	TWM 9000: -40... +140 °C / -40... +285 °F TWM 1000: -40... +120 °C / -40... +250 °F
Vacuum load	
0 mbar / 0 psi absolute	
Conductivity	
Non-water	≥ 5 μS/cm
Water	≥ 20 μ S/cm

Materials

Measuring tube													
Stainless steel 1.4301 (AISI 304)													
Housing													
Stainless steel 1.4462 (Duplex)													
Stainless steel 1.4301 (AISI 304)													
Connection box (F-versions only)													
Aluminum, polyurethane coated													
Stainless steel 1.4408 (AISI)													
Adapters													
Stainless steel 1.4404 (AISI 316L)													
	Note: other materials on request												

Nominal diameter													
[inch]	1/10"	1/8"	1/4"	3/8"	1/2"	1"	1 1/2"	2"	2 1/2"	3"	4"	5"	6"
[mm]	2.5	4	6	10	15	25	40	50	65	80	100	125	150

Liner													
PFA (FDA conform)													
Electrodes													
Hastelloy C4													
Hastelloy B2													
Platinum													
Stainless steel 1.4404 (AISI 316 L)													
Stainless steel 1.4571 (AISI 316 Ti)													
Tantalum													
Titanium													
Gaskets													
EPDM													
Silicone (non-Ex only)													
Note: FDA recommends EPDM gaskets only if product < 8% fat.													

Process connections

DIN 11850 row 2 / 11866 row A													
DIN 11851													
DIN 11864-2a flange with notch													
DIN 32676													
ISO 2037													
ISO 2852													
ISO 2853													
SMS 1145													
TRI CLOVER													
Note: DN2.5... 6 (1/10... 1/4") have DN10 (3/8") connections.													

Dimensions and Weights

Nominal diameter													
[inch]	1/10"	1/8"	1/4"	3/8"	1/2"	1"	1 1/2"	2"	2 1/2"	3"	4"	5"	6"
[mm]	2.5	4	6	10	15	25	40	50	65	80	100	125	150

Approvals

3A													
EHEDG													
Non-Ex													
EEx zone 1/2													
FM – class I div.2													
CSA – GP / class I div.2													
SAA – Aus Ex zone 1/2													
TIIS – zone 1/2													
Protection category													
IP66 / 67 eq. NEMA 4/4X / 6													
IP68 field eq. NEMA 6P													
IP68 factory eq. NEMA 6P													

standard
 optional
 on request

Dimensions and Weights

DIN 11850 (row 2 or DIN 11866 row A)

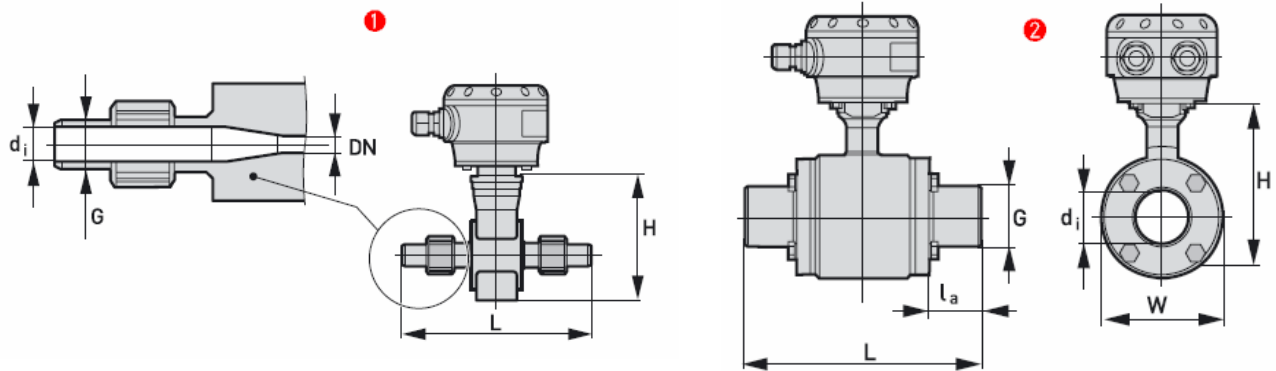

- (1) DN2.5...10 screwed adapter with DN10 process connections / DN15 screwed adapter
 (2) DN25...150 bolted adapter

Nominal size		Dimensions [mm]						Approx. weight	
		Adapter			Flowmeter				
DN	PN	d_i	G	l_a	L	H	W	[kg]	(lbs)
2.5	40	10	13	32	180	142	44	1.5	3.3
4	40	10	13	32	180	142	44	1.5	3.3
6	40	10	13	32	180	142	44	1.5	3.3
10	40	10	13	32	180	142	44	1.5	3.3
15	40	16	19	32	180	142	44	1.5	3.3
25	40	26	29	20.6	132.6	128	89	3	6.6
40	40	38	41	61.3	220	153	114	5.3	11.7
50	25	50	53	61.3	220	153	114	6.8	15
65	25	66	70	41.8	220	180	414	10.9	24
80	25	81	85	66.8	280	191	152	11.2	24.7
100	16	100	104	59.3	280	242	203	18.4	40.6
125	10	125	129	66.3	319	258	219	29.5	65.0
150	10	150	154	64.3	325	293	254	44.3	97.7

Dimensions and Weights

DIN 11851

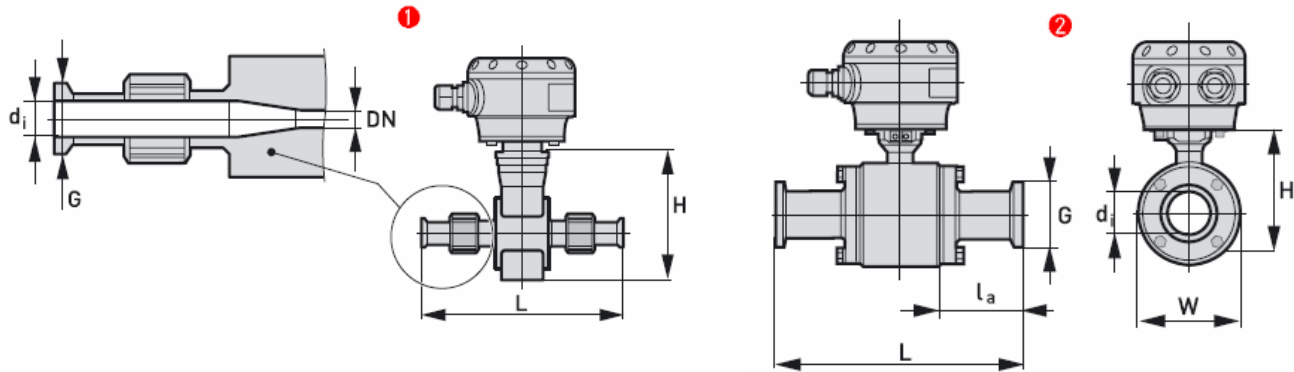

- (1) DN2.5...10 screwed adapter with DN10 process connections / DN15 screwed adapter
 (2) DN25...150 bolted adapter

Nominal size		Dimensions [mm]						Approx. weight	
		Adapter			Flowmeter				
DN	PN	d_i	G	l_a	L	H	W	[kg]	(lbs)
2.5	40	10	Rd 28 x 1/8"	53.1	214	142	44	1.5	3.3
4	40	10	Rd 28 x 1/8	53.1	214	142	44	1.5	3.3
6	40	10	Rd 28 x 1/8	53.1	214	142	44	1.5	3.3
10	40	10	Rd 28 x 1/8	53.1	214	142	44	1.5	3.3
15	40	16	Rd 34 x 1/8	53.1	214	142	44	1.5	3.3
25	40	26	Rd 52 x 1/6	49.3	190	128	89	3.2	7.1
40	40	38	Rd 65 x 1/6	91.3	280	153	114	5.5	12.1
50	25	50	Rd 78 x 1/6	93.3	284	153	114	5.3	11.7
65	25	66	Rd 95 x 1/6	77.8	292	180	414	10	22.1
80	25	81	Rd 110 x 1/4	107.8	362	191	152	12.5	27.6
100	16	100	Rd 130 x 1/4	109.3	380	242	203	21.8	48.1
125	10	On request							
150	10	On request							

Dimensions and Weights

DIN 11864-2A

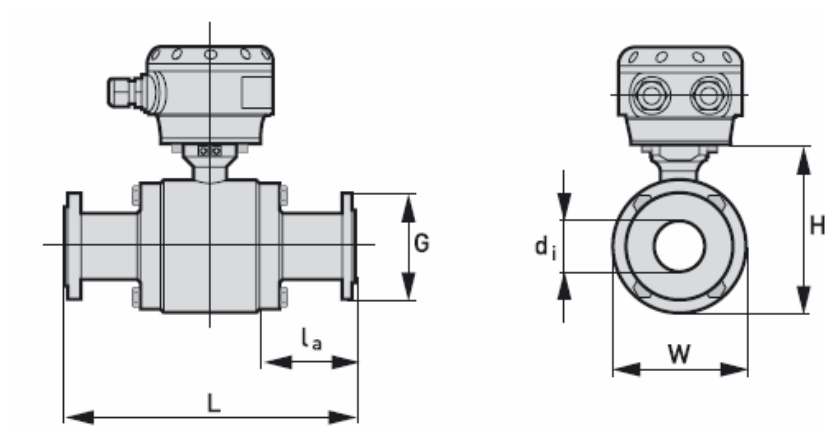

Nominal size		Dimensions [mm]						Approx. weight	
		Adapter			Flowmeter				
DN	PN	d_i	G	l_a	L	H	W	[kg]	(lbs)
25	40	26	70	45.8	183	128	89	4.4	9.7
40	40	38	82	83.3	264	153	114	7.5	16.5
50	25	50	94	83.3	264	153	114	9	19.8
65	25	66	113	63.8	264	180	141	14.5	32
80	25	81	133	122.8	392	191	152	18.6	41
100	16	100	159	115.3	392	242	203	28.2	62.2
125	10	On request							
150	10								

Note:

Meter supplied with flange with notch

Dimensions and Weights

DIN 32676

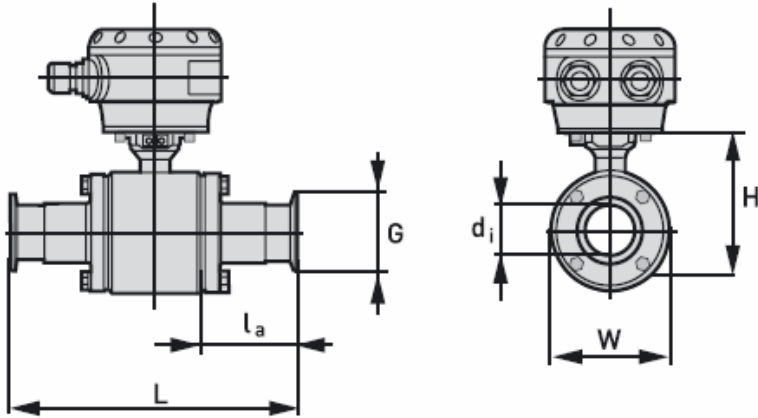

Nominal size		Dimensions [mm]						Approx. weight	
		Adapter			Flowmeter				
DN	PN	d_i	G	l_a	L	H	W	[kg]	(lbs)
25	16	26	50.5	41.8	190	128	89	3.2	7.1
40	16	38	50.5	80.8	280	153	114	5.5	12.1
50	16	50	64	80.8	284	153	114	5.3	11.7
65	16	66	91	67.8	292	180	141	10	22.1
80	16	81	106	92.8	362	191	152	12.5	27.6
100	16	100	119	85.3	380	242	203	21.8	48.1

Dimensions and Weights

ISO 2037

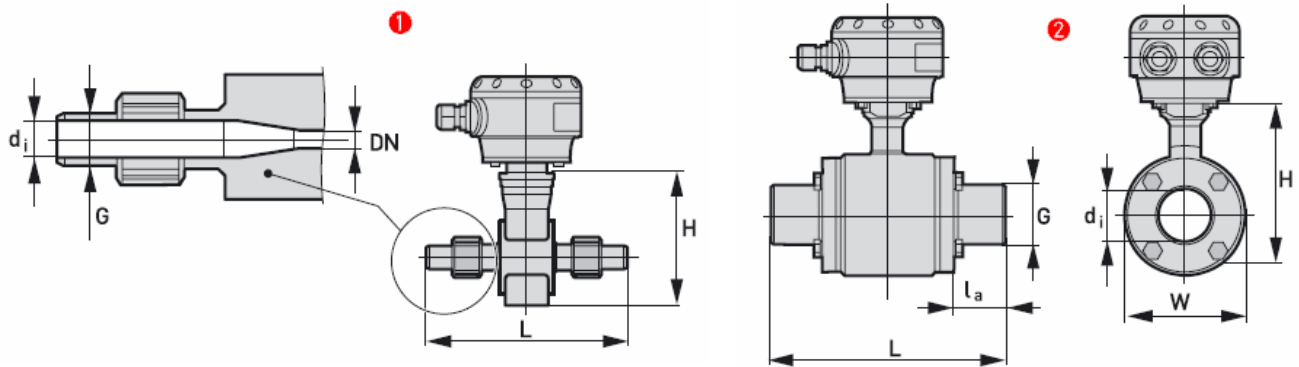

- (1) DN2.5...10 screwed adapter with DN10 process connections / DN17.2 screwed adapter
 (2) DN25...150 bolted adapter

Nominal size		Dimensions [mm]						Approx. weight	
		Adapter			Flowmeter				
DN	PN	d_i	G	l_a	L	H	W	[kg]	(lbs)
2.5	40	10	12	32	180	142	44	1.5	3.3
4	40	10	12	32	180	142	44	1.5	3.3
6	40	10	12	32	180	142	44	1.5	3.3
12	40	10	12	32	180	142	44	1.5	3.3
17.2	40	16	17.2	32	180	142	44	1.5	3.3
25	40	22.6	25	20.6	132.6	128	89	3	6.6
38	40	38	38	61.3	220	153	114	5.3	11.7
51	25	49	51	61.3	220	153	114	5	11
63.5	25	60.3	63.5	41.8	220	180	414	9	19.8
76.1	25	72.9	76.1	66.8	280	191	152	10.8	23.8
101.6	16	97.6	101.6	59.3	280	242	203	18.4	40.6
114.3	10	110.3	114.3	66.3	319	258	219	29.5	65.0
139.3	10	135.7	139.3	64.3	325	293	254	44.3	97.7

Dimensions and Weights

ISO 2852

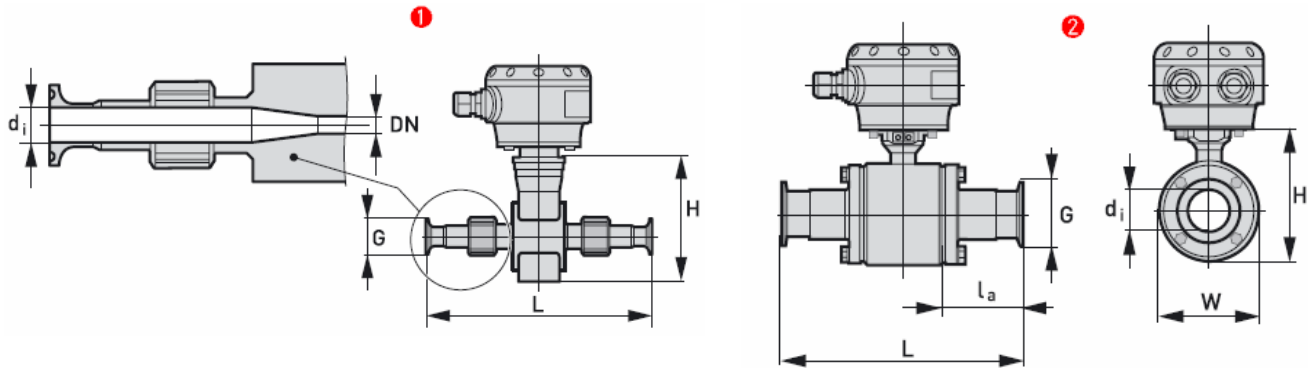

- (1) DN2.5...10 screwed adapter with DN10 process connections / DN17.2 screwed adapter
(2) DN25...150 bolted adapter

Nominal size		Dimensions [mm]						Approx. weight	
		Adapter			Flowmeter				
DN	PN	d_i	G	l_a	L	H	W	[kg]	(lbs)
2.5	16	10	34	51.6	219	142	44	1.8	4.0
4	16	10	34	51.6	219	142	44	1.8	4.0
6	16	10	34	51.6	219	142	44	1.8	4.0
12	16	10	34	51.6	219	142	44	1.8	4.0
17.2	16	16	34	51.6	219	142	44	1.8	4.0
25	16	22.6	50.5	41.8	175	128	89	3.3	7.3
38	16	35.6	50.5	87.8	273	153	114	5.4	11.9
50	16	48.6	64	87.8	273	153	114	5.2	11.5
63.5	10	60.3	77.5	68.3	273	180	141	9.5	20.9
71.1	10	72.9	91	93.3	333	191	152	11.2	24.7
101.6	8	97.6	119	85.8	333	242	203	19.1	42.1
125	5	On request							
150	5								

Dimensions and Weights

ISO 2853

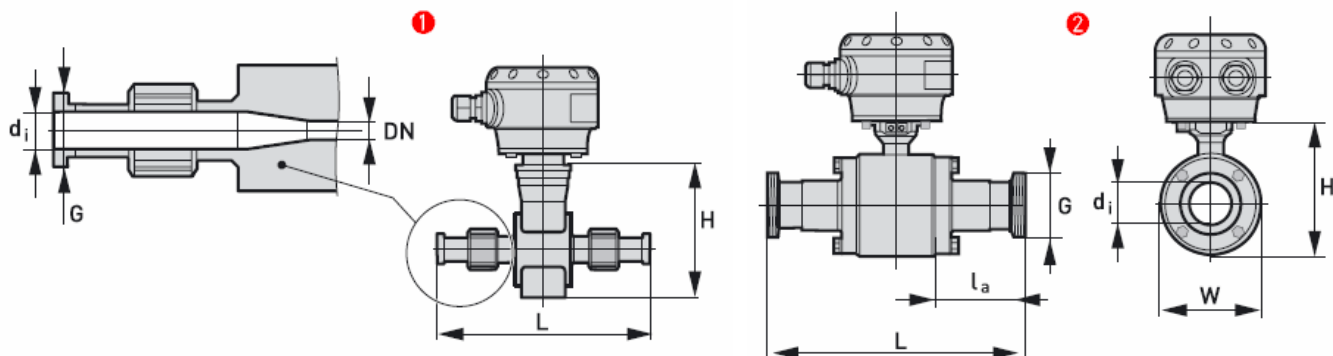

- (1) DN2.5...10 screwed adapter with DN10 process connections / DN15 screwed adapter
 (2) DN25...150 bolted adapter

Nominal size		Dimensions [mm]						Approx. weight	
		Adapter			Flowmeter				
DN	PN	d _i	G	l _a	L	H	W	[kg]	(lbs)
2.5	40	10	Rd 22.8 x 1/8"	53	226	142	44	3.1	6.8
4	40	10	Rd 22.8 x 1/8"	53	226	142	44	3.1	6.8
6	40	10	Rd 22.8 x 1/8"	53	226	142	44	3.1	6.8
10	40	10	Rd 22.8 x 1/8"	53	226	142	44	3.1	6.8
15	40	16	Rd 22.8 x 1/8"	53	226	142	44	3.1	6.8
25	40	22.6	Rd 37.1 x 1/8	45	226	131	80	4.4	9.7
38	40	35.6	Rd 56.6 x 1/8	49.5	253	149	98	6.1	13.5
51	25	48.6	Rd 64.1 x 1/8	51.5	263	181	130	7.6	16.8
63.5	25	60.3	Rd 77.6 x 1/8	50.5	309	206	156	11.7	25.8
76.1	25	72.9	Rd 91.1 x 1/8	50.5	309	206	156	12	26.5

Dimensions and Weights

Tri-Clover

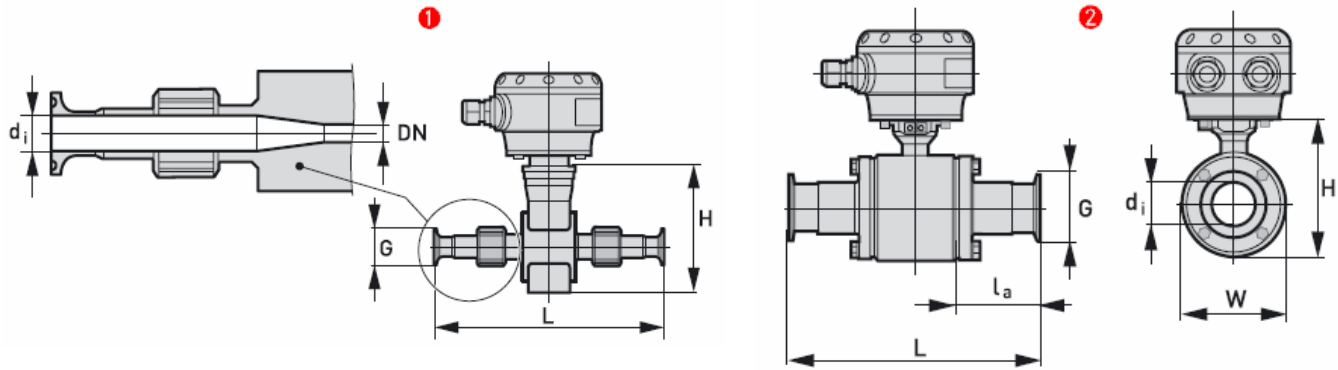

- (1) DN½"...¾" screwed adapter
(2) DN1"...4" bolted adapter

Nominal size		Dimensions [mm]						Approx. weight	
		Adapter			Flowmeter				
DN	PN	d _i	G	l _a	L	H	W	[kg]	(lbs)
½"	290	0.37	0.98	1.97	8.5	5.59	1.73	1.5	3.3
¾"	290	0.62	0.98	1.97	8.5	5.59	1.73	1.5	3.3
1"	290	0.85	1.98	1.02	7.48	5.04	3.5	3.2	7.1
1½"	290	1.35	1.98	3.46	11.02	6.02	4.49	5.5	12.1
2"	290	1.85	2.52	3.46	11.18	6.02	4.49	5.3	11.7
2½"	290	2.35	3.05	2.69	11.5	7.09	5.55	10	22.1
3"	290	2.85	3.54	3.68	14.25	7.52	5.98	12.5	27.6
4"	174	3.83	4.68	3.38	14.96	9.53	7.99	21.8	48.1

Dimensions and Weights

SMS 1145 Adapter

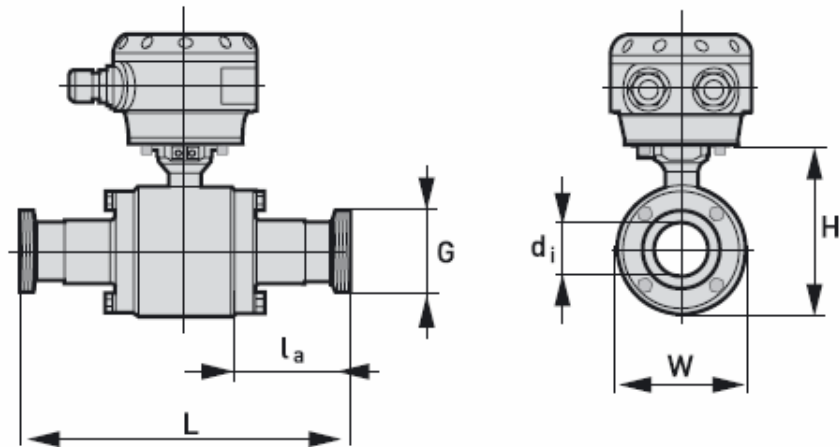

Nominal size		Dimensions [mm]						Approx. weight	
		Adapter			Flowmeter				
DN	PN	d _i	G	l _a	L	H	W	[kg]	(lbs)
25	6	22.6	Rd 40-6	28.1	147.6	128	89	3.2	7.1
38	6	35.5	Rd 60-6	54	262	153	114	5.7	12.6
51	6	48.6	Rd 70-6	84.3	266	153	114	5.4	11.9
63.5	6	60.3	Rd 85-6	69.8	276	180	141	9.9	21.8
76	6	72.9	Rd 98-6	99.8	346	191	152	12.1	26.7
100	6	97.6	Rd 132-6	44	336	242	203	21.9	48.3

Dimensions for different housing variations

Remote version connection box

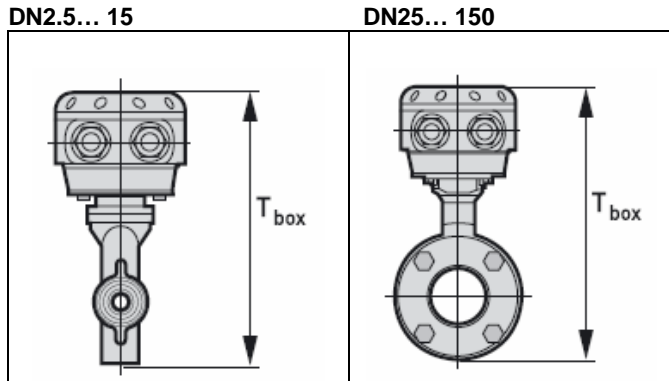

Compact version TWM 9000

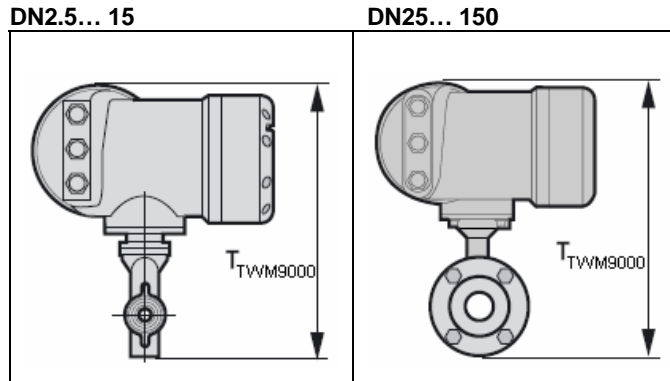

Compact version TWM 1000

TWM 1000 – 0° version

TWM 1000 - 45° version

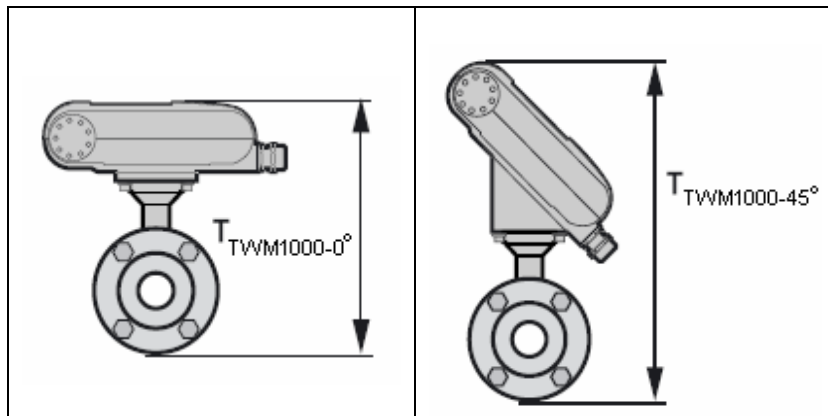

Nominal size		Dimensions [mm]				Dimensions [inch]			
DN	PN	T _{box}	T _{TWM1000-0°}	T _{TWM1000-45°}	T _{TWM9000}	T _{box}	T _{TWM1000-0°}	T _{TWM1000-45°}	T _{TWM9000}
2.5	40	200	205	309	302	7.87	8.07	12.17	10.94
4	40	200	205	309	302	7.87	8.07	12.17	10.94
6	40	200	205	309	302	7.87	8.07	12.17	10.94
10	40	200	205	309	302	7.87	8.07	12.17	10.94
15	40	200	205	309	302	7.87	8.07	12.17	10.94
25	40	205	210	314	283	8.08	8.28	12.36	11.14
40	40	230	235	339	308	9.05	9.25	13.35	12.13
50	25	230	235	339	308	9.05	9.25	13.35	12.13
65	25	257	262	366	335	10.11	10.31	14.41	13.19
80	25	268	273	377	346	10.55	10.75	14.84	13.62
100	16	319	324	428	397	12.56	12.76	16.85	15.63
125	10	335	340	444	413	13.19	13.39	17.48	16.26
150	10	370	375	479	448	14.56	14.76	18.86	17.64

По вопросам продаж и поддержки обращайтесь:

Астана +7(7172)727-132, Волгоград (844)278-03-48, Воронеж (473)204-51-73, Екатеринбург (343)384-55-89,
Казань (843)206-01-48, Краснодар (861)203-40-90, Красноярск (391)204-63-61, Москва (495)268-04-70,
Нижегород (831)429-08-12, Новосибирск (383)227-86-73, Ростов-на-Дону (863)308-18-15,
Самара (846)206-03-16, Санкт-Петербург (812)309-46-40, Саратов (845)249-38-78, Уфа (347)229-48-12

Единый адрес: hwn@nt-rt.ru
www.honeywell.nt-rt.ru