

VersaFlow Mag 2000 FL Electromagnetic Flow Sensor Technical Datasheet

34-VF-03-21
August 27th, 2008

Specification

Solution with high-tech ceramics

The VersaFlow Mag 2000 FLelectromagnetic flow sensor is the standard in accuracy. VersaFlow Mag 2000 FL is highly resistant against abrasion.

Figure 1 – VersaFlow Electromagnetic Flow Sensor

Highlights

- Excellent long-term stability and accuracy
- For most aggressive and abrasive fluids
- Fully vacuum-resistant
- High-tech ceramics liner
- Insensitive against temperature shocks

Industries

- Chemicals
- Pulp & Paper
- Water
- Wastewater
- Minerals & Mining

Applications

- Dosing and batching
- Electrolyte measurement for battery filling
- Dosing control
- Chemical injection
- Wastewater treatment

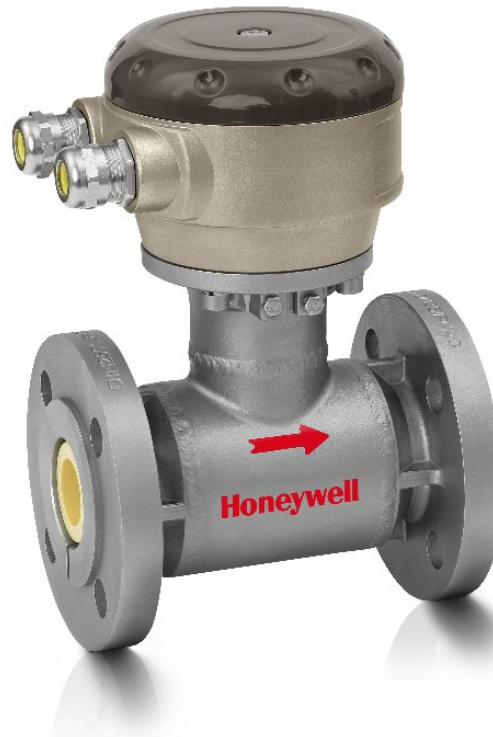

По вопросам продаж и поддержки обращайтесь:



Астана +7(7172)727-132, Волгоград (844)278-03-48, Воронеж (473)204-51-73, Екатеринбург (343)384-55-89,
Казань (843)206-01-48, Краснодар (861)203-40-90, Красноярск (391)204-63-61, Москва (495)268-04-70,
Нижегород (831)429-08-12, Новосибирск (383)227-86-73, Ростов-на-Дону (863)308-18-15,
Самара (846)206-03-16, Санкт-Петербург (812)309-46-40, Саратов (845)249-38-78, Уфа (347)229-48-12

Единый адрес: hwn@nt-rt.ru

www.honeywell.nt-rt.ru





Electromagnetic product range

VersaFlow converters: All converters fit to all sensors

		
<p>Integral Mounted</p>	<p>Field Mounted</p>	<p>Wall Mounted</p>

TWM 9000 High-performance solution

VersaFlow Sensors

				
<p>VersaFlow Mag 1000 Economical solution</p>	<p>VersaFlow Mag 1000 Economical solution</p>	<p>VersaFlow Mag 4000 Standard solution for the process industry</p>	<p>VersaFlow Mag 2000 Solution with high-tech ceramics</p>	<p>VersaFlow Mag 3000 Sanitary and hygienic solution</p>

Technical Data

Nominal diameter	MM52						MM53		
ASME [inch]	1/2"	1"	1 1/2"	2"	3"	4"	6"	8"	10"
DN [mm]	15	25	40	50	80	100	150	200	250

Nominal flange pressure

EN 1092-1 - PN40									
EN 1092-1 - PN16									
EN 1092-1 - PN10									
ASME B16.5 - 150lbs RF									
ASME B16.5 - 300lbs RF									

Measuring tube

Ceramic									
---------	--	--	--	--	--	--	--	--	--

Electrodes

Cermet									
Stainless steel 1,4571 (AISI 316 Ti)									
Platinum									
HC4									
Low noise (basis HC4, Ta, Ti)									

Rings / Gaskets

PTFE (integrated) / no gasket required									
Stainless steel 1,4404 (AISI 316L) Viton									
Hastelloy C4 / Viton									

Flanges

Stainless Steel AISI 316 (1.4408)									
Steel 37 – C22									

Materials

Flow sensor housing (PU coated)									
- stainless steel AISI 316 (1.4408)									
- sheet steel									
Flow converter housing (compact design)									
- die cast aluminium (PU coated)									
- stainless steel AISI 304 (1.4306)									
Connection boxes (separate design)									
- die cast aluminium (PU coated)									
- stainless steel AISI 3040 (1.4306)									
	Other materials on request								

Protection category

IP 66/67 eq. NEMA 4/4X / 6									
IP 68 field eq. NEMA 6P									
IP 68 factory eq. NEMA6P									
	IP68 only available with stainless steel connection box								

Nominal diameter	MM52						MM53			
	ASME [inch]	1/2"	1"	1 1/2"	2"	3"	4"	6"	8"	10"
DN [mm]	25	25	40	50	80	100	150	200	250	

Approvals

Non-Ex										
EEx zone 1 / 2										
FM - class I div. 1 / 2										
CSA – GP / class I div. 1/2										
	Please note the approval are for flow sensors only									

Versions

Compact+ TWM 9000 C										
Separate+ TWM 9000 F, R, W										

Conductivity

≥ 1 μS/cm (non-water)										
≥ 5 μS/cm (non-water)										
≥ 20 μS/cm (demineralised cold water)										

standard
 optional
 on request

Dimensions and Weights

Nominal size		Dimensions [mm]					Approx. weight
DN	PN	L	H	W	T		[kg]
[mm]	[bar]				box	TWM9000	

DN2.5...100

15	40	150	127	95	205	282	3
25	40	150	143	115	221	298	4
40	40	150	168	150	246	323	6
50	40	200	184	165	262	339	9
80	40	200	217	200	295	372	15
100	16	250	248	235	326	403	21

DN150...250

150	16	265	355	283	426	-	37
200	10	315	396	342	467	-	53
250	10	365	458	395	529	-	87

Nominal size		Dimensions 150 lbs [inch]					Approx. weight
DN	PN	L	H	W	T		[lbs]
[mm]	[bar]				box	TWM9000	

DN1/2"...4"

1/2"	580	5.91	5.00	3.74	8.07	11.1	1.36
1"	580	5.91	5.63	4.53	8.7	11.73	1.81
1 1/2"	580	5.91	6.61	5.91	9.69	12.72	2.72
2"	580	7.87	7.24	6.5	10.31	13.35	4.08
3"	580	7.87	8.54	7.87	11.61	14.65	6.8
4"	232	9.84	9.76	9.25	12.83	15.87	9.52

DN6"...10"

6"	232	10.43	13.98	11.14	16.77	-	16.78
8"	145	12.4	15.59	13.46	18.39	-	24.03
10"	145	14.37	18.03	15.55	20.83	-	39.45
		DN6"...10": Total fitting length: L + 2x 0.12" + 2x gasket thickness (flowmeter with separate rings)					

Frontview VersaFlow Mag 2000 F

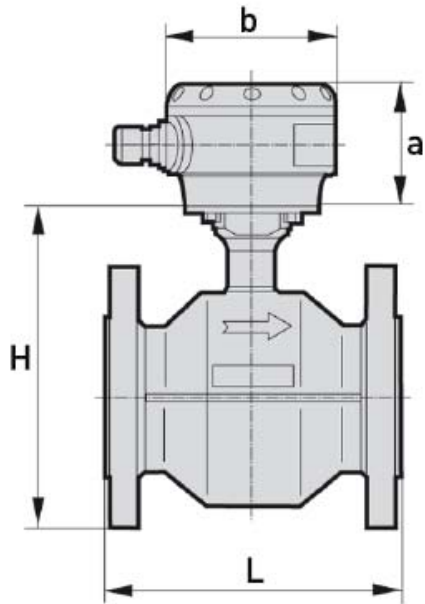

Sideview VersaFlow Mag 2000 F

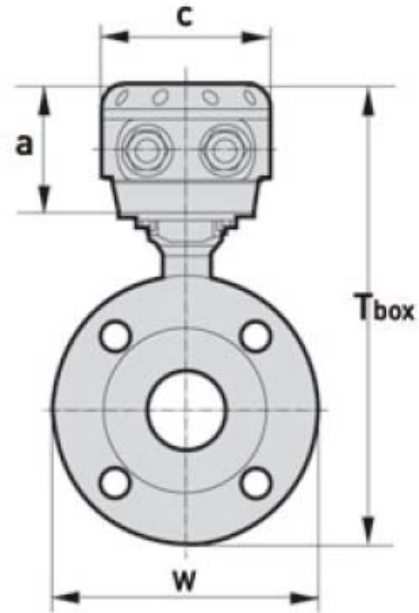

Frontview VersaFlow Mag 2000 Compact

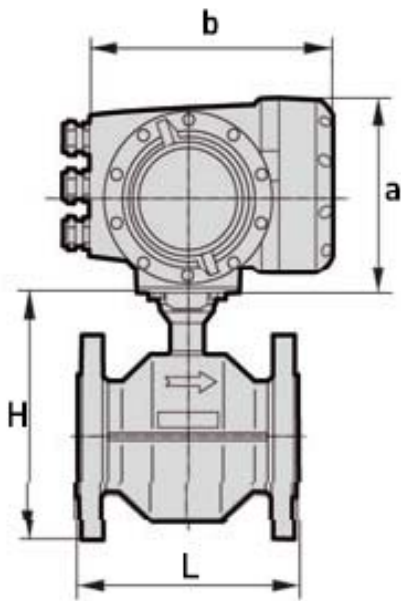

Sideview VersaFlow Mag 2000 Compact

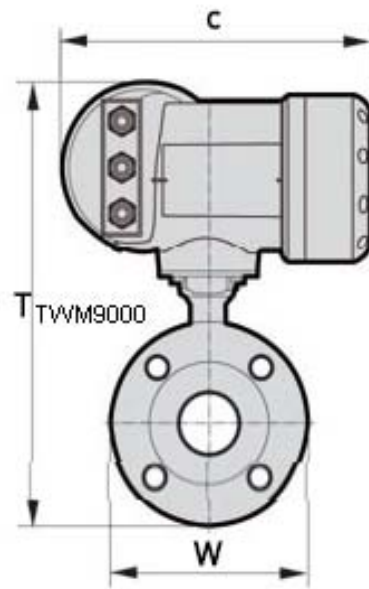

Dimensions housing

Type	Dimension a		Dimension b		Dimension c	
	(mm)	(inch)	(mm)	(inch)	(mm)	(inch)
Connection box	77	3.1	111	4.4	106	4.2
Compact converter	155	6.1	202	7.8	260	10.2

Temperature range

Temperature range	Process (°C)		Ambient (°C)		Process (°F)		Ambient (°F)	
	Min.	Max.	Min.	Max.	Min.	Max.	Min.	Max.

DN2.5... 100

Separate flow sensor	-60	180	-40	65	-76	356	-40	149
Compact+TWM 9000	-60	140	-40	65	-76	284	-40	149

DN150... 250

Separate flow sensor	-60	120	-25	60	-76	248	-13	140
----------------------	-----	-----	-----	----	-----	-----	-----	-----

Temperature change	10 minutes (°C)		Sudden change (°C)		10 minutes (°F)		Sudden change (°F)	
	rising	falling	rising	falling	rising	falling	rising	falling
DN15... 100	150	100	120	80	302	212	248	176
DN150... 250	150	80	100	60	302	176	212	140

По вопросам продаж и поддержки обращайтесь:
 Астана +7(7172)727-132, Волгоград (844)278-03-48, Воронеж (473)204-51-73, Екатеринбург (343)384-55-89,
 Казань (843)206-01-48, Краснодар (861)203-40-90, Красноярск (391)204-63-61, Москва (495)268-04-70,
 Нижний Новгород (831)429-08-12, Новосибирск (383)227-86-73, Ростов-на-Дону (863)308-18-15,
 Самара (846)206-03-16, Санкт-Петербург (812)309-46-40, Саратов (845)249-38-78, Уфа (347)229-48-12
 Единый адрес: hwn@nt-rt.ru
 www.honeywell.nt-rt.ru